

All Wide Range



VP ELECTRONIQUE

# Programmable DC Power Supply

World's First Wide-Range Input and Wide-Range Output



Solar Array Simulator

DSP-WS

DSP-WAs

DC Power Supply

DSP-WR

DSP-WE

DSP-WA

DSP-WAe

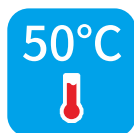

台灣精品 2021  
TAIWAN EXCELLENCE

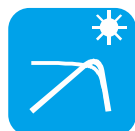

## Environmental Mission / iDRC and the Environment

We are devoted to product innovation and development while also protecting the environment and maintaining our social responsibility. We focus on reducing the impact to the environment throughout the product lifecycle, during product design, material use, manufacturing, packaging, product use and recycling.

### ● Purpose of Design

Our goal in designing our products is to allow every customer to have more efficient use of energy and be able to obtain power in an environmentally friendly way. Our products help our customers precisely design and develop their own remarkable energy efficient products.



Our products include DC Power Supplies, AC Power Sources, and Power Analyzers. They are primarily used in wind, solar, and other green power energy research and development laboratories, and all kinds of electric vehicles, home appliances, and IT products. We help all of our customers to design and develop low energy consumption products that meet industry standards and help reduce gas emissions.



### ● Eliminating Toxic Materials/Substances

We are very strict in selecting materials that we use. We do not use any harmful or toxic substances in our products or packaging. All our products and packaging strictly follow the rules of RoHS Directive, WEEE, and other environmental laws and regulations. We avoid using harmful toxins, we also seek to exclude the possibility of using harmful materials in our products.

### ● High Efficiency

Throughout our development process we strive to meet our goals of high energy efficiency. We use low energy consumption equipment for design, for example information equipment that meets EAP energy efficiency requirements. We use power regeneration load when testing and manufacturing to reduce energy consumption. We also select low-power components and apply the latest technology to reduce energy conversion losses. Applying Active Power Factor Correct (APFC) into the products makes the PF of the products higher than 0.95 which improves the electricity quality of each product and reduces the energy waste by 20-50%.

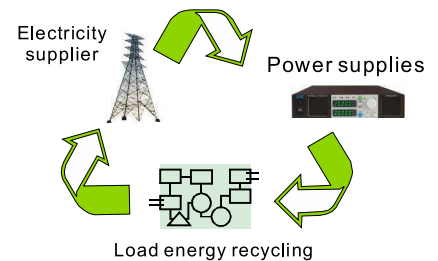

### ● Smaller Volume, Less energy waste

Designing small, compact, efficient products is another way iDRC reduces energy consumption. More compact products require fewer packaging materials and allow more efficient transportation. CO2 emissions produced during transportation are efficiently reduced.



### ● Life

Our high quality components and iDRC's proprietary design provide greater durability and reliability. A longer product life means reduced CO2 emissions and waste produced during transportation, maintenance, and replacement. A longer product life provides our customers with reduced life-cycle costs through flexibility and reliability.



### ● Recycle

The recyclability of our products is higher than 85%. That means the impact of non-recyclable components on the environment is reduced.

## Innovation

After decades of research and development, iDRC has been granted 290 patents (through October 2022), including more than 57 invention patents. The DSP-Wx series benefits from over 200 patents, including the "HOME/BACK" multifunction key, the Output switch control system, and Synchronization circuitry. These features make the DSP-Wx family the industry leaders in programmable DC power supplies.



## DSP-WR Patents

(Total 201 patents including 39 invention patents)

China	ZL 2014 2 0064432.4, ZL 2014 2 0539916.X, ZL 2014 3 0130259.9, ZL 2014 3 0490203.4, ZL 2014 3 0490204.9, ZL 2015 2 0136770.9, ZL 2015 2 0150534.2, ZL 2015 2 0229375.5, ZL 2015 2 0573475.X, ZL 2015 2 0573543.2, ZL 2015 3 0432790.6, ZL 2015 3 0435062.0, ZL 2015 1 0071335.7, ZL 2016 2 0154125.4, ZL 2016 2 0353605.3, ZL 2016 2 0358539.9, ZL 2016 2 0639352.6, ZL 2016 3 0005985.7, ZL 2016 3 0060739.1, ZL 2016 3 0135663.4, ZL 2017 1 0756181.4, ZL 2017 3 0134857.7, ZL 2018 2 0225014.7, ZL 2018 2 1265923.X, ZL 2018 3 0482951.6, ZL 2018 3 0482965.8, ZL 2018 3 0483295.1, ZL 2018 3 0483561.0, ZL 2018 3 0483597.9, ZL 2018 3 0693371.1, ZL 2019 2 0371250.4, ZL 2019 2 0389562.8, ZL 2019 3 0706094.8, ZL 2020 2 0252037.4, ZL 2020 2 0700402.3, ZL 2021 2 0577034.2, ZL 2021 3 0051475.4, ZL 2017 3 0601155.5, ZL 2017 3 0659600.3, ZL 2018 2 0461773.3, ZL 2018 2 0801460.8, ZL 2019 2 0405909.3, ZL 2019 1 0949831.6
Germany	Nr 10 2015 002824.3, Nr 10 2017 008 759, Nr 10 2020 123618.2, Nr 20 2013 011 929.2, Nr 20 2014 100 958.2, Nr 20 2014 104 818.9, Nr 20 2015 102 036, Nr 20 2015 103 503, Nr 20 2015 103 504, Nr 20 2015 105 008, Nr 20 2015 105 009, Nr 20 2016 101 440.9, Nr 20 2016 102 507, Nr 20 2016 102 535, Nr 20 2016 103 687, Nr 20 2018 000 645, nr 20 2018 001 864, Nr 20 2018 002 885, Nr 20 2018 003 769, Nr 20 2019 001 474, Nr 20 2019 001 672, Nr 20 2019 001669, Nr 20 2020 101 721, Nr 20 2020 102 962, Nr 20 2021 105 656, Nr. 20 2020 005 508
European Union	002468934-0001, 002597591-0001, 002597617-0001, 002844431-0001, 002847640-0001, 002941997-0001, 003004233-0001, 003076587-0001, 003935154-0001, 004508851-0001, 004561694-0001, 005616596-0001, 005616638-0001, 005616646-0001, 005616679-0001, 005616687-0001, 005831799-0001, 007772942-0001, 008229447-0001, 008418511-0001, 008418511-0001
Japan	3215943, 1631063, 1631064, 3220684, 3220912, 3221909, 3222336, 6633722, 6639599, 3227818, 3229187, 1689613, 7016005, 1711352, 3238001
Taiwan	D 170155, D 172385, D 172386, D 174708, D 186590, D 196231, D 196232, D177237, D177781, D180503, D184678, D187992, D191439, D195785, D195786, D197453, D204982, D212629, D214445, I 472141, I 530981, I 741716, I610507, I722518, M 512157, M486210, M490169, M500915, M504972, M505753, M512253, M520767, M524947, M524948, M524949, M558454, M560044, M566456, M569109, M577968, M582224, M593686, M598027, M618029, I770853
United Kingdom	90030042330001, 90030765870001, 6130954
United States	US 10,063,038, US 10,123,442 B1, US 10,264,709 B1, US 10,383,245 B1, US 10,547,161 B1, US 10,609,846 B1, US 10,788,159 B1, US 10,925,173 B1, US 11,108,243 B1, US 11,116,115 B1, US 11,183,776 B2, US 9,240,730 B2, US 9,287,769 B1, US 9,489,011 B2, US 9,513,500 B2, US 9,538,679 B1, US 9,621,066 B2, US 9,632,548 B1, US 9,674,973 B1, US 9,681,564 B2, US 9,748,055, US 9,787,189, US 9,801,292, US D735,149S, US D770396, US D771577, US D779,837 S, US D782,417 S, US D782,424 S, US D785,710 S, US D785,711 S, US D815,608, US D848,945 S, US D870,678 S, US D870,679, US D870,681 S, US D870,682, US D870,683, US D881,825 S, US D881,910 S, US D925,479 S, US D937,888 S, US 11,316,422 B1

## Guarantee

iDRC commits to producing the highest quality products. We use industry leading test equipment to aid our designs and verify our results.

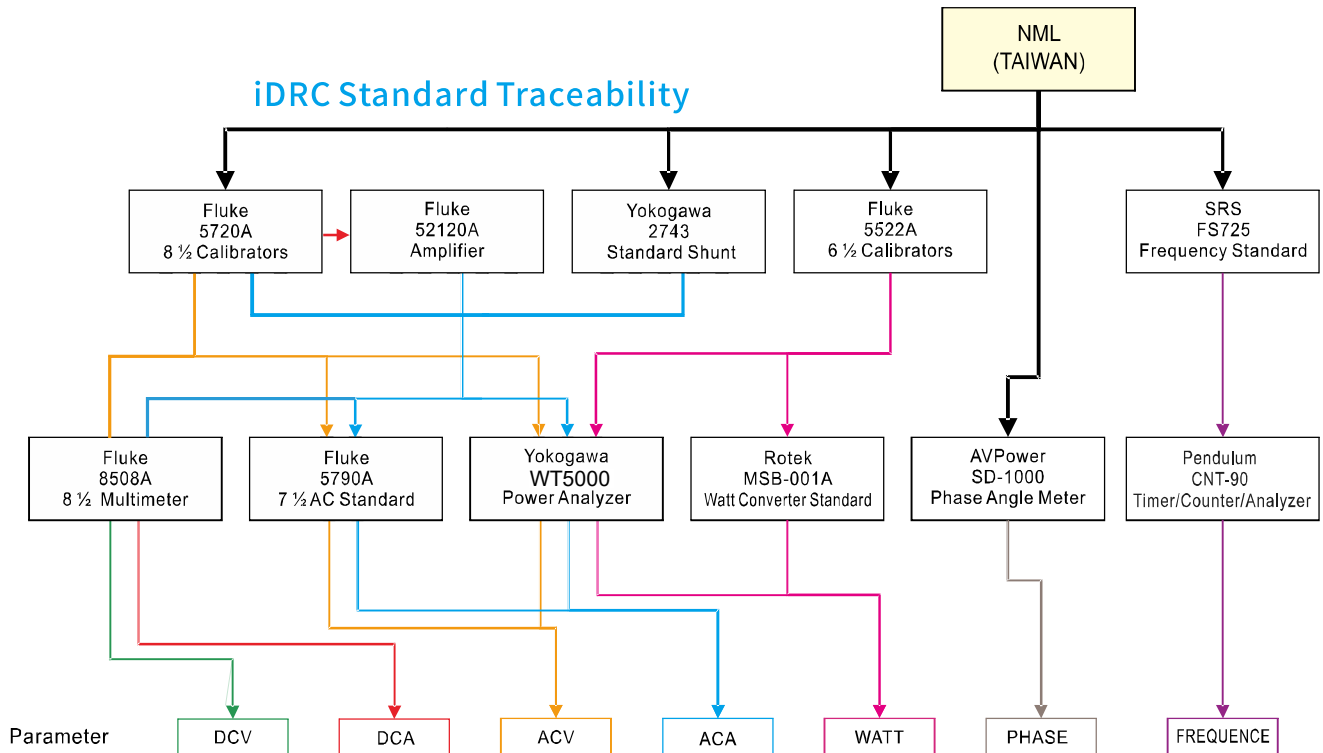

## Calibration Equipment

**FLUKE** : 5720A , 5700A , 5522A , 5520A , 5500A , 52120A , 5790A , 8508A 、 **HP** 3458A 、 **Guildline** 7620 、  
**SRS** : FS725 , SR620 、 **Pendulum** CNT-90 、 **Yokogawa** : WT3000 , 2743 [2A , 5A , 10A , 20A , 50A , 100A] 、  
**Danisense** Fluxgate DCCT : 600A , 700A , 2000A 、 **LEM** Ultrastab DCCT : 60A , 150A , 600A , 700A , 1000A ,  
 5000A 、 **ROTEK** MSB-001A 、 **AVPower** SD-1000 ..etc.

## Development Instrumentation

**Keysight/Agilent/HP** : PA2201A , PA2203A , MSOX6004A , 53230A , 33522B , B2962A , 34470A , 34420A ,  
 34461A , 34401A , L4534A , L4532A , U1620A , 3245A , 4284A+42841A 、 **ADCMT** 7461A 、  
**AudioPrecision** APx525 、 **Fluke** : 8842A , 8846A , 190-104 、 **Tektronix** : 370A , TPS2024 , TPS2014 、  
**Keithley** : 2000 , 2015 、 **Hioki** : 3390 , 3196 , 3197 , PW3198 、 **IWATSU** : CS3100 , CS3200 , CS3300 ,  
 DG-8000 , VOAC7602 、 **Kikusui** : TOS-9201 , TOS-6200 , TOS-7200 , TOS-3200 , TOS-5101 、  
**Lecroy** : WR66Zi-HRO , HDO6104A-MS , MDA810A , DA1855A , DA1855A-PR2 、 **NF** : FRA5097 , FRA5087 ,  
 WF1948 , WF1974 , WF1946 , CK1620 、 **R&S** AM300 、 **SRS** DS360 、 **Tabor** WW2074 、 **Yokogawa** : WT3000 ,  
 WT1800 , PX8000 , DL750 , SB5710 , SL1000 , DL7480 ..etc.

note: The names and logos mentioned in this catalog are the property of the mentioned companies

# Safety certification

## Electromagnetic Compatibility

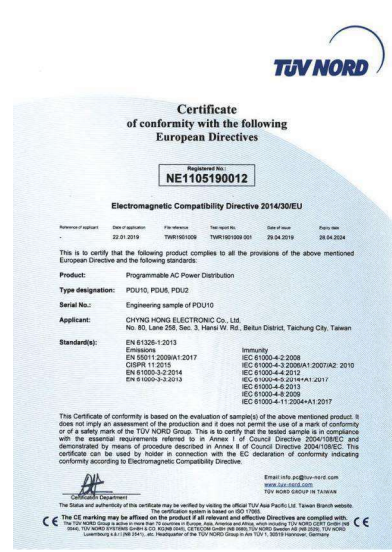
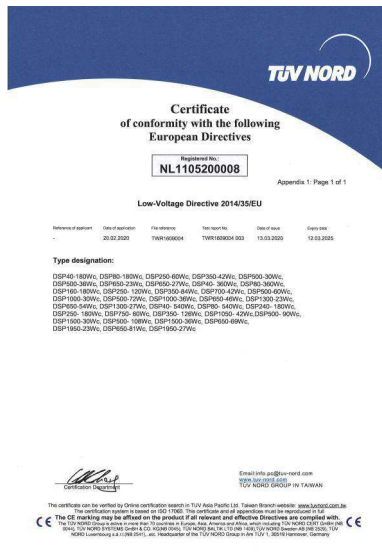
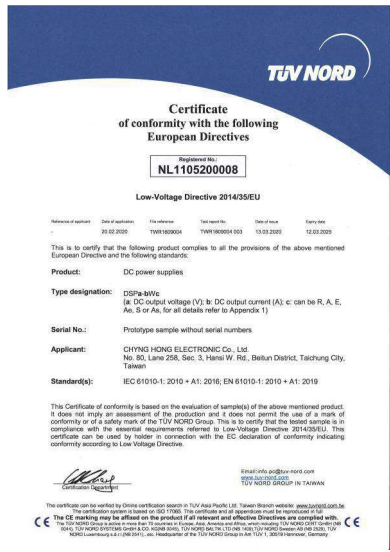

DSP-Wx series

PDU series

## Low Voltage Directive

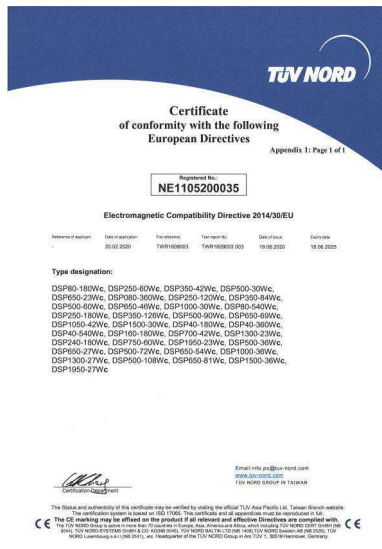

DSP-Wx series

PDU series

## Vibration Test & Filled Transport Packages

**KING DESIGN** Reliability & Communication Testing Instruments

**KING DESIGN INDUSTRIAL CO., LTD. VIBRATION LABORATORY**

4F, No. 3, Lane 278, Pui Sheu Road, Sec. 3, Hsinshui W. Rd., Beitun District, Taichung City, Taiwan, R.O.C.

TEL: 886-4-2437-6288 FAX: 886-4-2437-6286

TESTING / INSPECTION REPORT

REPORT NO : VT-170718-1

COMPANY : CHYNG HONG ELECTRONIC CO., LTD.

ADDRESS : No.80, Lane 258, Sec. 3, Hsinshui W. Rd., Beitun District, Taichung City, Taiwan.

TEL : 886-4-2437-6288

FAX : 886-4-2437-6286

SPECIMEN : Package

DATE OF RECEIVED : 2017/07/14

DATE OF TESTED : 2017/07/14

TEST / INSPECTION ITEMS : Package Random Vibration Test, Package Drop Test

REMARKS :

- The Laboratory is accredited by ISO/IEC 17025 General Requirements for the Competence of Calibration and Testing Laboratory.
- The results only apply to the device under test.
- This report is 17 pages, and no part of it may be abstracted or reproduced.

Test Engineer : Ken Wu

Approval Signature: David Lee, Laboratory Head: Chong

**KING DESIGN** Reliability & Communication Testing Instruments

**KING DESIGN INDUSTRIAL CO., LTD. VIBRATION LABORATORY**

4F, No. 3, Lane 278, Pui Sheu Road, Sec. 3, Hsinshui W. Rd., Beitun District, Taichung City, Taiwan, R.O.C.

TEL: 886-4-2437-6288 FAX: 886-4-2437-6286

TESTING / INSPECTION REPORT

TESTING EQUIPMENT :

Vibration Tester : KING DESIGN KD-EM-5000F2-75N600

S/N : KD1H51103

Calibration Date : 2016/11/25

Recommended Recal Date : 2017/11/24

Vibration Controller : Crystal Instruments Spider-81, S/N : 985952

Control Accelerometer : Wilson Research WR-780C, S/N : 04388

Calibration Date : 2016/11/11

Recommended Recal Date : 2017/11/10

TEST ENVIRONMENT :

Temperature : 25 °C (25±10°C)

Relative Humidity : 61%RH (50±25% RH)

SPECIMEN :

Model : Package

Package Dimension : 630 x 330 x 960 mm

Total Weight : 49.38kg

Quantity : 1 unit

**KING DESIGN** Reliability & Communication Testing Instruments

**KING DESIGN INDUSTRIAL CO., LTD. VIBRATION LABORATORY**

4F, No. 3, Lane 278, Pui Sheu Road, Sec. 3, Hsinshui W. Rd., Beitun District, Taichung City, Taiwan, R.O.C.

TEL: 886-4-2437-6288 FAX: 886-4-2437-6286

TESTING / INSPECTION REPORT

TEST SPECIFICATION :

(3) Package Random Vibration Test

Test Condition: Ref. IEC 60068-2-64

Frequency : 1 Hz to 200 Hz

Acceleration : 1.15G rms

Frequency (Hz)	G/Hz (PSD Level)
1.0	0.0001
4.0	0.01
100.0	0.01
200.0	0.001

Test Axis : 30 minutes for Face 3; 10 minutes for Face 1, Face 2 and Face 5

(4) Package Drop Test

Test condition : JIS Z 0200:2013

Drop Height : 30cm (300mm)

Drop Onto : 1 corner, 3 edges, 6 faces

TEST RESULT :

Function judgement	PASS	FAIL	Non-Judgment <sup>(1)</sup>
Appearance check	✓		

(1) - This test report record object test procedure and environment, not including test result.

DSP-Wx series

# 5/10/15 · 6/12/18kW Wide Range Programmable DC Power Supply

## DSP-WR / WE Series



### DSP-WR Series



- >95% High Efficiency
- 0.99 PF (AC480V 3Ø Input)
- MHz Interleave Technology
- 5" 800x480LCD+Touch Screen
- Intuitive Human Interface

## DSP-WA / WAe Series

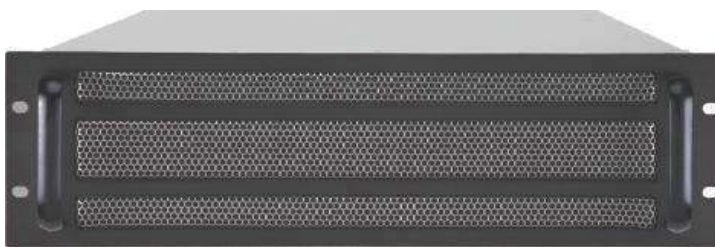

- LED Indicators
- Appropriate for ATE
- MAIN / SUBSidiary Unit

## Features

- **All Wide Range**; AC mains 180~460V, DC output 0~80V/540A to 0~1950V/27A.
- Each DSP-Wx can contain up to three power modules. Each power module runs on 3-phase Vac input, keeping the AC mains in balance, and complying with worldwide power distribution standards.
- 32 models give a range of power output from 5kW to 18kW.
- Built-in, patented synchronizing circuitry allows easy integration of 100 units to form an 1800kW power system.
- Active power factor correction, PF>0.99(480V input).
- Efficiency >95%+. (\*2)

## Electrical

- MHz switching frequency (15kW and 18kW models) with extremely low output ripple and noise.(\*3)
- Multiple 32-bit ARM based embedded system gives a rapid boot of 10 seconds or less.
- Wide Bandgap power semiconductors such as the SiC MOSFET SBD give better performance, higher efficiency, and lower heat dissipation, increasing the range of acceptable ambient temperatures for use.
- Adjustable output voltage, current and power.
- Constant Voltage(CV), Constant Current(CC) and Constant Power(CP) , CV. CC. or CP working priority setting.
- Internal resistance adjustment function allows battery simulation.
- Provide True RMS current and True Watt readings.
- 18 bit DAC for Setting and 24 bit ADC for Measurement.
- Built-in Real Time Clock gives reliable time even when disconnected from a time server.
- It is possible to customize time synchronization to a time server.
- Remote sense functionality compensation voltage up to 5V.

## Operational

- 5" touch screen with 3 definable background colors, 3 spin knobs with push-select and two push buttons give a clear and intuitive control.
- Patented multi-function HOME/RETURN key.
- Patented output ON/OFF button gives an extra layer of safety, allowing powered output only when both internal switches are triggered.
- Two kinds of output mode which can be changed following adjustment or after confirmation.
- Programmable over-voltage and over-current protection.
- Programmable output ramp-up and ramp-down protect the device under test.
- Up to 8000 sets of V/A/W data at 1ms intervals can be recorded and stored.
- Three sets of settings can be stored and recalled from the front panel.
- Free software gives control and sequence data setting.
- Data logging is timestamped.

## Safety

- All models automatically discharge voltage to a safe range within 10 seconds of output being switched off.
- User definable power ON mode (LAST \ Output OFF or ON)
- Closed-case firmware upgrading and enhanced protection to prevent upgrade failures.
- Intelligent stepless speed controlled fans reduce acoustic noise while keeping system temperature low.
- Systems are shipped in CE approved, Filled Transport Packages approved, and Vibration Test approved shipping cases.

## Interface

- Two LAN ports(LXI 1.4 approved) minimize wiring and reduce network complexity.
- Interface slot allows optional GPIB, RS422+485+USB, or Isolated Analog connections.
- Supports SCPI commands.
- Provides IVI-COM driver.
- Alarm signal output and Interlock mechanism prevent possible injury.
- Optional isolated analog programming port, 0~5V or 0~10V for setting and monitoring output V/A/W.
- USB port gives easy data access. (\*4)
- Free graphical connection and control software. (\*5)
- Customized software gives an easy comparison between wide-range and traditional DC power supplies. (\*5)

## High Power/Current/Voltage Wide Range Output meet all Applications

- |                                |                       |                          |                   |
|--------------------------------|-----------------------|--------------------------|-------------------|
| ● Aerospace and Satellite Test | ● Battery Testing     | ● Sputtering and Coating | ● Heat Processing |
| ● Semiconductor Equipments     | ● Vehicle Electronics | ● Chemical Treatment     | ● QC Testing      |
| ● Solar Cell/Array Application | ● DC to DC Convertors | ● Water Purification     | ● LED Testing     |
| ● Contact/Connector Testing    | ● DC to AC Invertors  | ● Electronic Anti-rust   | ● Lighting        |
| ● Telecom and IT Industries    | ● New Energy R&D      | ● Factory Automation     | ● MOCVD           |
| ● Automated Test Equipment     |                       |                          |                   |

note : \*1: The ratio varies by model.

\*2: The efficiency varies by model and input voltage.

\*3: MHz switching frequency on selective models.

\*4: The format of USB flash drive should be FAT16(2GB) or FAT32(32GB) USB2.0).

\*5: Software available at iDRC website [www.idrc.com.tw](http://www.idrc.com.tw)

## Output Characteristic

The DSP-Wx series provides various voltage and current combinations at full power. This makes the DSP-Wx useful in a broader range of applications, replacing multiple traditional DC power supplies.

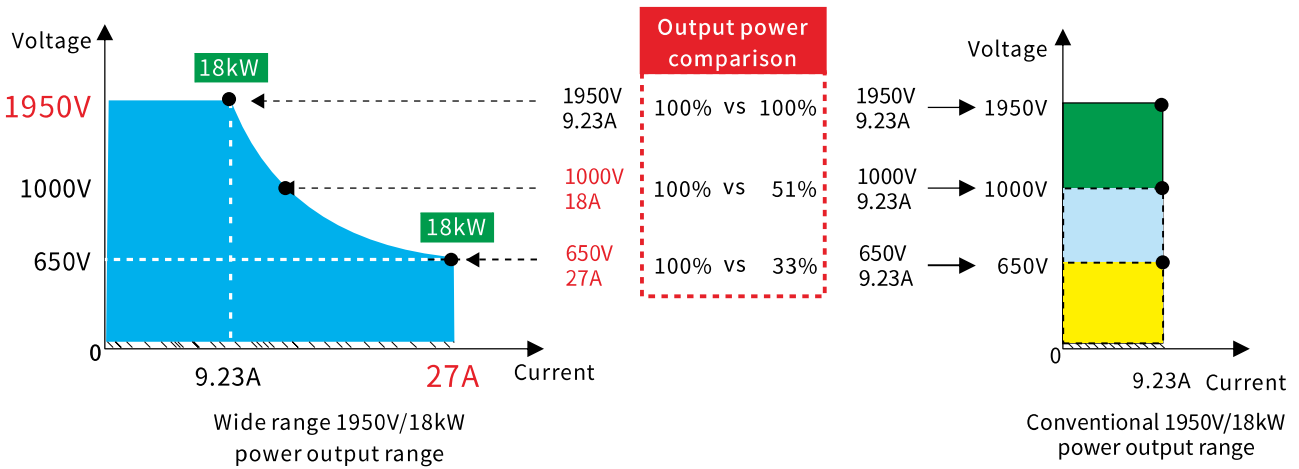

## Power rating (DSP-WR / DSP-WE / DSP-WA / DSP-WAe)

Output Power (32 models)	Models	Max. Voltage	Current @ Max. Voltage	Voltage @ Max. Current	Max. Current
		V1	A1	V2	A2
5kW (5 models)	DSP80-180□□	80 V	62.5 A	27.77 V	180 A
	DSP250-60□□	250 V	20 A	83.33 V	60 A
	DSP350-42□□	350 V	14.28 A	119.04 V	42 A
	DSP500-30□□	500 V	10 A	166.66 V	30 A
	DSP650-23□□	650 V	7.69 A	217.39 V	23 A
10kW (8 models)	DSP80-360□□	80 V	125 A	27.77 V	360 A
	DSP160-180□□	160 V	62.5 A	55.55 V	180 A
	DSP250-120□□	250 V	40 A	83.33 V	120 A
	DSP350-84□□	350 V	28.57 A	119.04 V	84 A
	DSP500-60□□	500 V	20 A	166.66 V	60 A
	DSP650-46□□	650 V	15.38 A	217.39 V	46 A
	DSP1000-30□□	1000 V	10 A	333.33 V	30 A
15kW (9 models)	DSP1300-23□□	1300 V	7.69 A	434.78 V	23 A
	DSP80-540□□	80 V	187.5 A	27.77 V	540 A
	DSP250-180□□	250 V	60 A	83.33 V	180 A
	DSP350-126□□	350 V	42.85 A	119.04 V	126 A
	DSP500-90□□	500 V	30 A	166.66 V	90 A
	DSP650-69□□	650 V	23.07 A	217.39 V	69 A
	DSP750-60□□	750 V	20 A	250 V	60 A
	DSP1050-42□□	1050 V	14.28 A	357.14 V	42 A
6kW (2 models)	DSP1500-30□□	1500 V	10 A	500 V	30 A
	DSP1950-23□□	1950 V	7.69 A	650 V	23 A
12kW (4 models)	DSP500-36□□	500 V	12 A	166.66 V	36 A
	DSP650-27□□	650 V	9.23 A	222.22 V	27 A
	DSP500-72□□	500 V	24 A	166.66 V	72 A
	DSP650-54□□	650 V	18.46 A	222.22 V	54 A
18kW (4 models)	DSP1000-36□□	1000 V	12 A	333.33 V	36 A
	DSP1300-27□□	1300 V	9.23 A	444.44 V	27 A
	DSP500-108□□	500 V	36 A	166.66 V	108 A
	DSP650-81□□	650 V	27.69 A	222.22 V	81 A
	DSP1500-36□□	1500 V	12 A	500 V	36 A
	DSP1950-27□□	1950 V	9.23 A	666.66 V	27 A

\* Any output power combination from V1 x A1 to V2 x A2 is possible, but V1 x A2 is not allowed.



## Block Diagram

### Power Module

The power module of the DSP-Wx series uses a state-of-the-art SiC MOSFET/SBD and full 3-stage structure, with the following features :

1. 3-phase line input keeps AC mains balanced and conforms with worldwide power distribution standards.
2. Forms 10-18kW models by internal series or parallel.
3. All power modules (up to 3) inside the unit are controlled by a single CV/CC circuit, eliminating chasing during transition.
4. Full 3 stage structure delivers the best efficiency with synergy efficiencies near 96%.
5. The 1st stage (APFC) has a two-phase interleaved design which gives high frequency, high density, high efficiency and low distortion.
6. The 2nd stage is an isolated, 99% high-efficiency DC to DC converter.
7. The 3rd stage is a buck circuit, consisting of 3 sets of interleaved SiC MOSFETs with a working frequency of up to 333 kHz.
8. The working frequency of 15/18kW models are up to 1MHz based on 3x3 phases interleaved

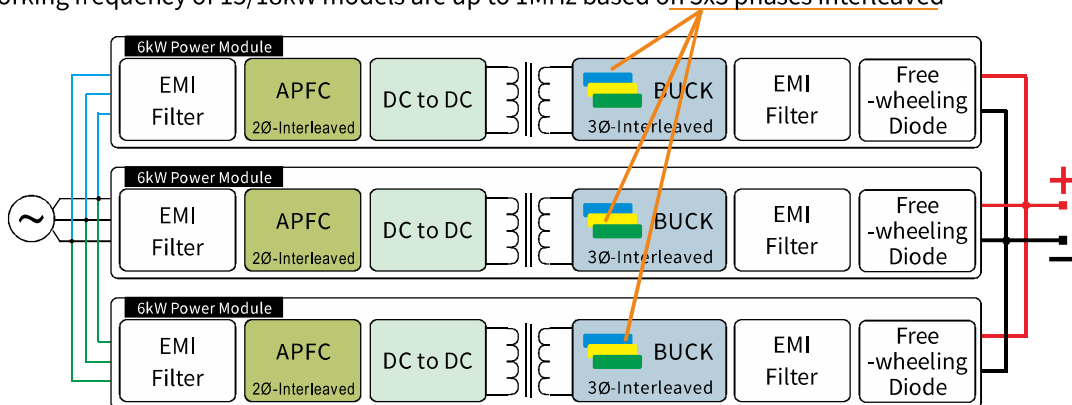

### Control Module

1. The DSP-Wx series uses multiple 32-bit RAM MCUs and embedded RTOS. Each major control circuit has a dedicated embedded processor to ensure the highest performance, delivering the fastest response time in the industry.
2. Each control module signal and power circuit is completely isolated, delivering the best noise protection to ensure measurement accuracy and control stability.
3. The DSP-Wx series uses a Cortex M4 CPU to drive the built-in network capability for Main/SUBsidiary control. This design allows the DSP-Wx family to parallel more than 100 units to form high output power systems, without additional devices.

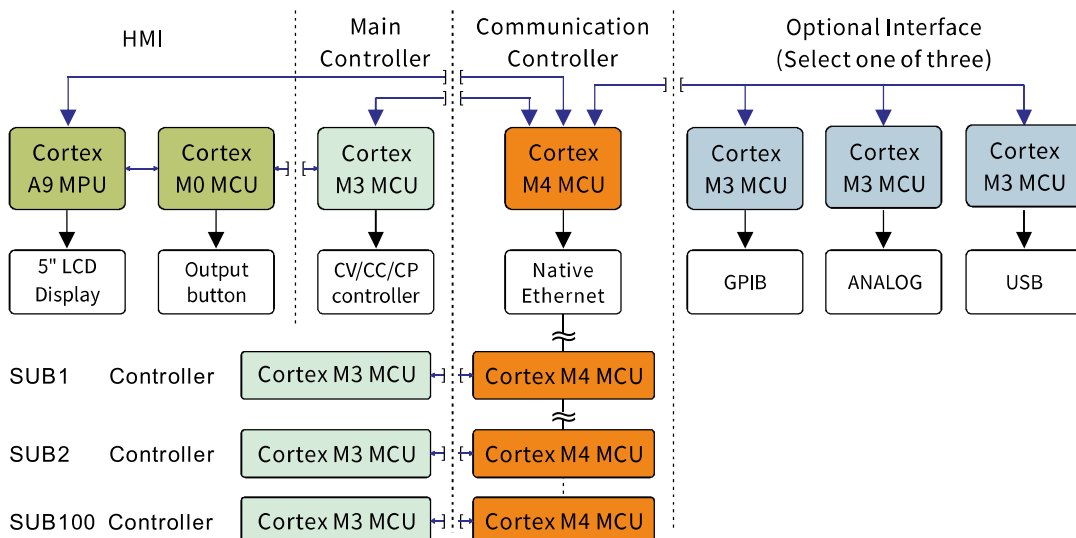

## Techniques Comparison

iDRC's decades of research and development allow us to offer DC power supplies that are significantly more efficient and environmentally friendly. Compared with traditional DC power supplies, our DSP-Wx series systems offer:

- **15%** higher efficiency
- **1/6** of Size
- **1/2** of Weight
- **15** times faster

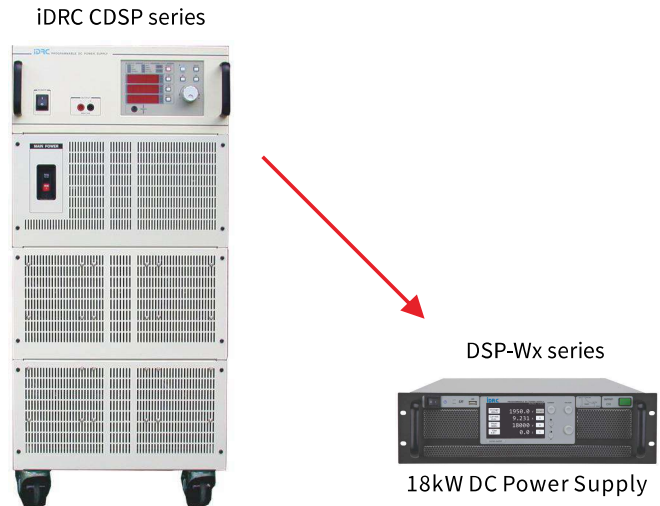

## MHz Switching Frequency

The DSP-Wx multi-phase interleaved design boosts switching frequency to 1 MHz. The higher frequency allows the system to output with minimal ripple and respond to load variations faster than other systems. The DSP-Wx series is the first programmable DC power supply to reach MHz switching frequencies.

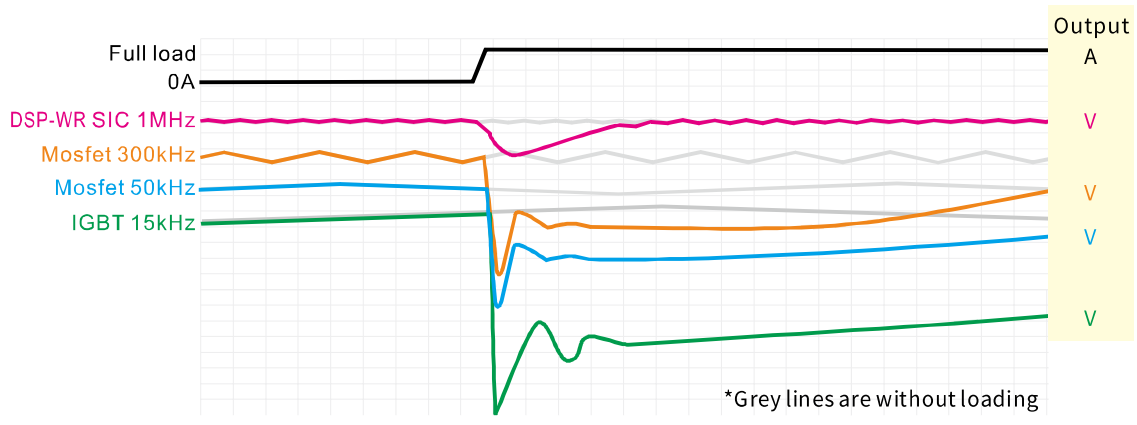

## Adjustable Output On/Off Slope

The output slope is based on the Slew Rate setup. If the Ramp Up/Down is more rapid than the Slew Rate, the DSP-Wx will default to Slew Rate settings. In the example below, the Ramp Up setting is higher than the Slew Rate, so the output voltage increases more gradually.

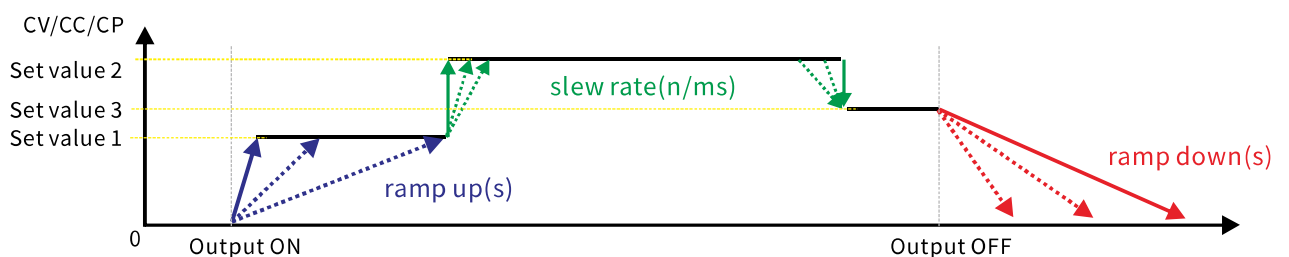

\*1. Exact Ramp Down time may be affected by settings and load characteristics.

## Output Slew Rates

The DSP-Wx series power supplies allow you to specify the slew rates for Voltage, Current, and Power. The supported slew rates are shown in the charts below.

### 1. Setting ranges for Voltage slew rates :

Model	80V	160V	250V	350V	500V
5kW	0.008V/ms ~ 80V/ms	--	0.025V/ms ~ 250V/ms	0.035V/ms ~ 350V/ms	0.05V/ms ~ 500V/ms
6kW	--	--	--	--	0.05V/ms ~ 500V/ms
10kW	0.008V/ms ~ 80V/ms	0.016V/ms ~ 160V/ms	0.025V/ms ~ 250V/ms	0.035V/ms ~ 350V/ms	0.05V/ms ~ 500V/ms
12kW	--	--	--	--	0.05V/ms ~ 500V/ms
15kW	0.008V/ms ~ 80V/ms	--	0.025V/ms ~ 250V/ms	0.035V/ms ~ 350V/ms	0.05V/ms ~ 500V/ms
18kW	--	--	--	--	0.05V/ms ~ 500V/ms

Model	650V	750V	1000V	1050V	1300V
5kW	0.065V/ms ~ 650V/ms	--	--	--	--
6kW	0.065V/ms ~ 650V/ms	--	--	--	--
10kW	0.065V/ms ~ 650V/ms	--	0.1V/ms ~ 1000V/ms	--	0.13V/ms ~ 1300V/ms
12kW	0.065V/ms ~ 650V/ms	--	0.1V/ms ~ 1000V/ms	--	0.13V/ms ~ 1300V/ms
15kW	0.065V/ms ~ 650V/ms	0.075V/ms ~ 750V/ms	--	0.105V/ms ~ 1050V/ms	--
18kW	0.065V/ms ~ 650V/ms	--	--	--	--

Model	1500V	1950V
15kW	0.15V/ms ~ 1500V/ms	0.195V/ms ~ 1950V/ms
18kW	0.15V/ms ~ 1500V/ms	0.195V/ms ~ 1950V/ms

### 2. Setting ranges for Current slew rates :

Model	80V	160V	250V	350V	500V
5kW	0.018A/ms ~ 180A/ms	--	0.006A/ms ~ 60A/ms	0.0042A/ms ~ 42A/ms	0.003A/ms ~ 30A/ms
6kW	--	--	--	--	0.0036A/ms ~ 36A/ms
10kW	0.036A/ms ~ 360A/ms	0.018A/ms ~ 180A/ms	0.012A/ms ~ 120A/ms	0.0084A/ms ~ 84A/ms	0.006A/ms ~ 60A/ms
12kW	--	--	--	--	0.0072A/ms ~ 72A/ms
15kW	0.054A/ms ~ 540A/ms	--	0.018A/ms ~ 180A/ms	0.0126A/ms ~ 126A/ms	0.009A/ms ~ 90A/ms
18kW	--	--	--	--	0.0108A/ms ~ 108A/ms

Model	650V	750V	1000V	1050V	1300V
5kW	0.0023A/ms ~ 23A/ms	--	--	--	--
6kW	0.0027A/ms ~ 27A/ms	--	--	--	--
10kW	0.0046A/ms ~ 46A/ms	--	0.003A/ms ~ 30A/ms	--	0.0023A/ms ~ 23A/ms
12kW	0.0054A/ms ~ 54A/ms	--	0.0036A/ms ~ 36A/ms	--	0.0027A/ms ~ 27A/ms
15kW	0.0069A/ms ~ 69A/ms	0.006A/ms ~ 60A/ms	--	0.0042A/ms ~ 42A/ms	--
18kW	0.0081A/ms ~ 81A/ms	--	--	--	--

Model	1500V	1950V
15kW	0.003A/ms ~ 30A/ms	0.0023A/ms ~ 23A/ms
18kW	0.0036A/ms ~ 36A/ms	0.0027A/ms ~ 27A/ms

### 3. Setting ranges for Power slew rates :

Model	80V	160V	250V	350V	500V
5kW	0.5W/ms ~ 500W/ms	--	0.5W/ms ~ 500W/ms	0.5W/ms ~ 500W/ms	0.5W/ms ~ 500W/ms
6kW	--	--	--	--	0.6W/ms ~ 600W/ms
10kW	1W/ms ~ 1000W/ms	1W/ms ~ 1000W/ms	1W/ms ~ 1000W/ms	1W/ms ~ 1000W/ms	1W/ms ~ 1000W/ms
12kW	--	--	--	--	1.2W/ms ~ 1200W/ms
15kW	1.5W/ms ~ 1500W/ms	--	1.5W/ms ~ 1500W/ms	1.5W/ms ~ 1500W/ms	1.5W/ms ~ 1500W/ms
18kW	--	--	--	--	1.8W/ms ~ 1800W/ms

Model	650V	750V	1000V	1050V	1300V
5kW	0.5W/ms ~ 500W/ms	--	--	--	--
6kW	0.6W/ms ~ 600W/ms	--	--	--	--
10kW	1W/ms ~ 1000W/ms	--	1W/ms ~ 1000W/ms	--	1W/ms ~ 1000W/ms
12kW	1.2W/ms ~ 1200W/ms	--	1.2W/ms ~ 1200W/ms	--	1.2W/ms ~ 1200W/ms
15kW	1.5W/ms ~ 1500W/ms	1.5W/ms ~ 1500W/ms	--	1.5W/ms ~ 1500W/ms	--
18kW	1.8W/ms ~ 1800W/ms	--	--	--	--

Model	1500V	1950V
15kW	1.5W/ms ~ 1500W/ms	1.5W/ms ~ 1500W/ms
18kW	1.8W/ms ~ 1800W/ms	1.8W/ms ~ 1800W/ms

\*1. Exact Slew Rate may be affected by other settings and load characteristics.

\*2. For an explanation of Slew Rate, please refer to page 9 "Adjustable Output On/Off Slope."

\*3. For higher Slew Rates, please contact iDRC.

## Output Protection

The DSP-Wx series is fully protected from Reverse EMF through thoughtful design, as shown below. The freewheeling diodes are rated 20% above any anticipated load.

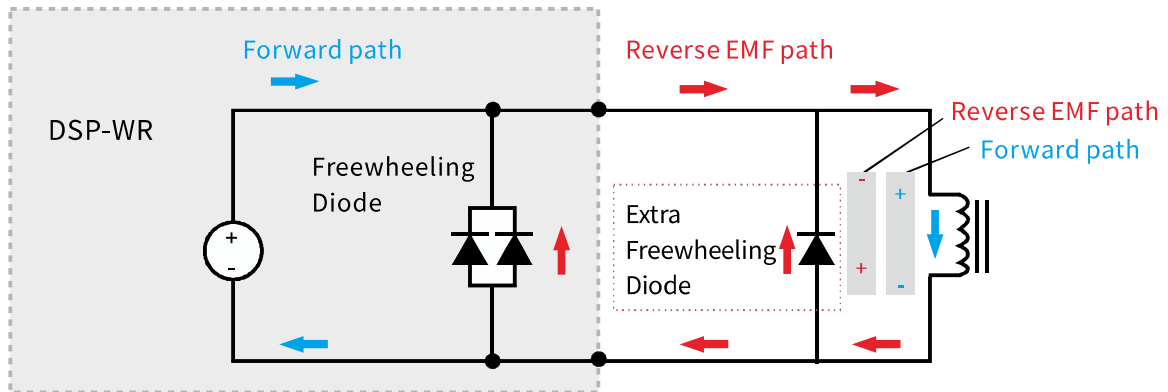

## Clear and Definite OUTPUT ON/OFF Control

iDRC products are designed from a user's perspective. We have replaced a confusing keypad with one large, clear OUTPUT ON/OFF button. Internally, the DSP-Wx series has safety interlocks to protect both DUT and personnel.

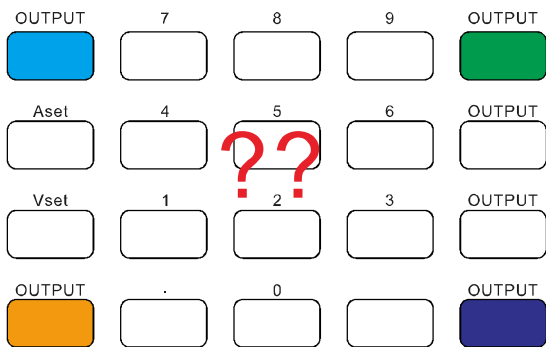

VS.



(Traditional all-in-one key pad with unclear symbol.)

## Maximum Power

1. DSP-WX Series Output Rating at 50°C Ambient Temperature.
2. 5kW/10kW/15kW Models Output Rating Power with 200-415Vac Lines
3. 6kW/12kW/18kW Models Output Rating Power with 380Vac Line, retain 83.33% of Rating Power with 200-240Vac Lines.

Model	200V	208V	220V	230V	240V	380V	400V	440V
5kW	5kW	5kW	5kW	5kW	5kW	5kW	5kW	5kW
10kW	10kW	10kW	10kW	10kW	10kW	10kW	10kW	10kW
15kW	15kW	15kW	15kW	15kW	15kW	15kW	15kW	15kW
6kW	5kW	5kW	5kW	5kW	5kW	6kW	6kW	6kW
12kW	10kW	10kW	10kW	10kW	10kW	12kW	12kW	12kW
18kW	15kW	15kW	15kW	15kW	15kW	18kW	18kW	18kW

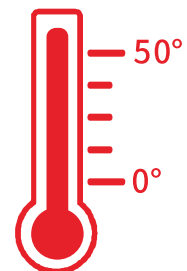

## Output Capacitance

model	80V	160V	250V	350V	500V	650V	750V	1000V	1050V	1300V	1500V	1950V
5kW	4230μF	--	1350μF	738μF	115μF	115μF	--	--	--	--	--	--
6kW	--	--	--	--	115μF	115μF	--	--	--	--	--	--
10kW	8460μF	2115μF	2700μF	1476μF	230μF	230μF	--	57.5μF	--	57.5μF	--	--
12kW	--	--	--	--	230μF	230μF	--	57.5μF	--	57.5μF	--	--
15kW	12690μF	--	4050μF	2214μF	345μF	345μF	450μF	--	246μF	--	38.3μF	38.3μF
18kW	--	--	--	--	345μF	345μF	--	--	--	--	38.3μF	38.3μF

## Auto-discharge

The DSP-Wx series automatically dissipates energy to about 60V or less within 10 seconds of Output OFF.

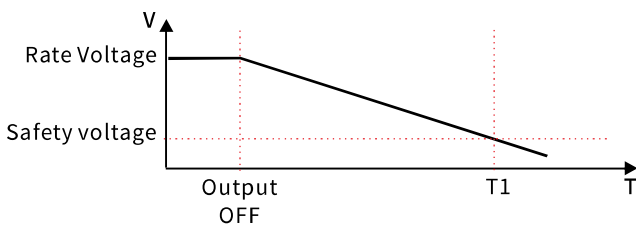

No load down time

Model	T1	Model	T1	Model	T1
80V	5 sec	650V	6 sec	1500V	5 sec
160V	10 sec	750V	10 sec	1950V	6 sec
250V	10 sec	1000V	5 sec		
350V	10 sec	1050V	10 sec		
500V	5 sec	1300V	6 sec		

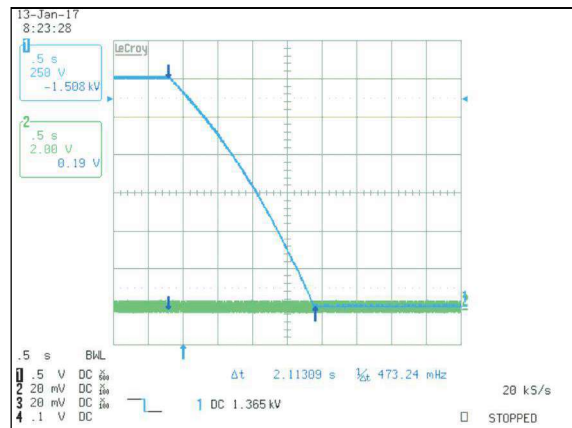

DSP1500-30WR 2.11 seconds discharging time at no loading

## Internal Resistance Simulation

The DSP-Wx series includes built-in resistance simulation allowing users to replicate battery behavior, accurate to 5 digits.

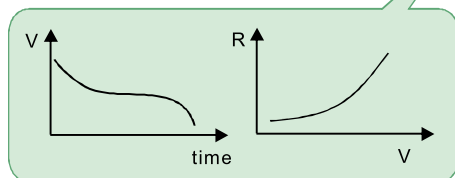
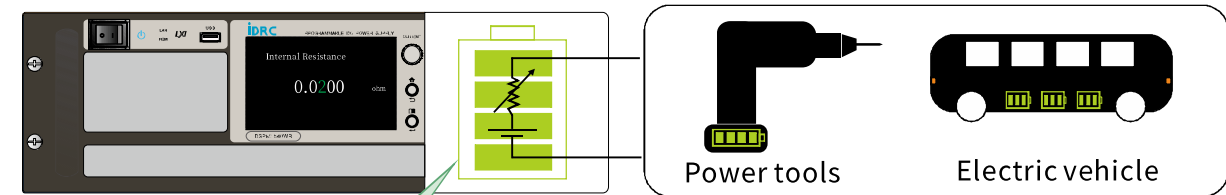

5kW model	Internal R range
DSP80-180Wx	0~0.4444Ω
DSP250-60Wx	0~4.1667Ω
DSP350-42Wx	0~8.3333Ω
DSP500-30Wx	0~16.667Ω
DSP650-23Wx	0~28.261Ω

6kW model	Internal R range
DSP500-36WR	0 ~ 13.888Ω
DSP650-27WR	0 ~ 24.074Ω

10kW model	Internal R range
DSP80-360Wx	0 ~ 0.2222Ω
DSP160-180Wx	0 ~ 0.8888Ω
DSP250-120Wx	0 ~ 2.0833Ω
DSP350-84Wx	0 ~ 4.1667Ω
DSP500-60Wx	0 ~ 8.3333Ω
DSP650-46Wx	0 ~ 14.130Ω
DSP1000-30Wx	0 ~ 33.333Ω
DSP-1300-23Wx	0 ~ 56.521Ω

12kW model	Internal R range
DSP500-72Wx	0 ~ 6.9444Ω
DSP650-54Wx	0 ~ 12.037Ω
DSP1000-36Wx	0 ~ 27.777Ω
DS1300-27Wx	0 ~ 48.148Ω

15kW model	Internal R range
DSP80-540Wx	0 ~ 0.1481Ω
DSP250-180Wx	0 ~ 1.3889Ω
DSP350-126Wx	0 ~ 2.7778Ω
DSP500-90Wx	0 ~ 5.5556Ω
DSP650-69Wx	0 ~ 9.4203Ω
DSP750-60Wx	0 ~ 12.500Ω
DSP1050-42Wx	0 ~ 25.000Ω
DSP1500-36Wx	0 ~ 50.000Ω
DSP1950-23Wx	0 ~ 84.782Ω

18kW model	Internal R range
DSP500-108Wx	0 ~ 4.6296Ω
DSP650-81Wx	0 ~ 8.0246Ω
DSP1500-36Wx	0 ~ 41.666Ω
DSP1950-27Wx	0 ~ 72.222Ω

Ultimate Components

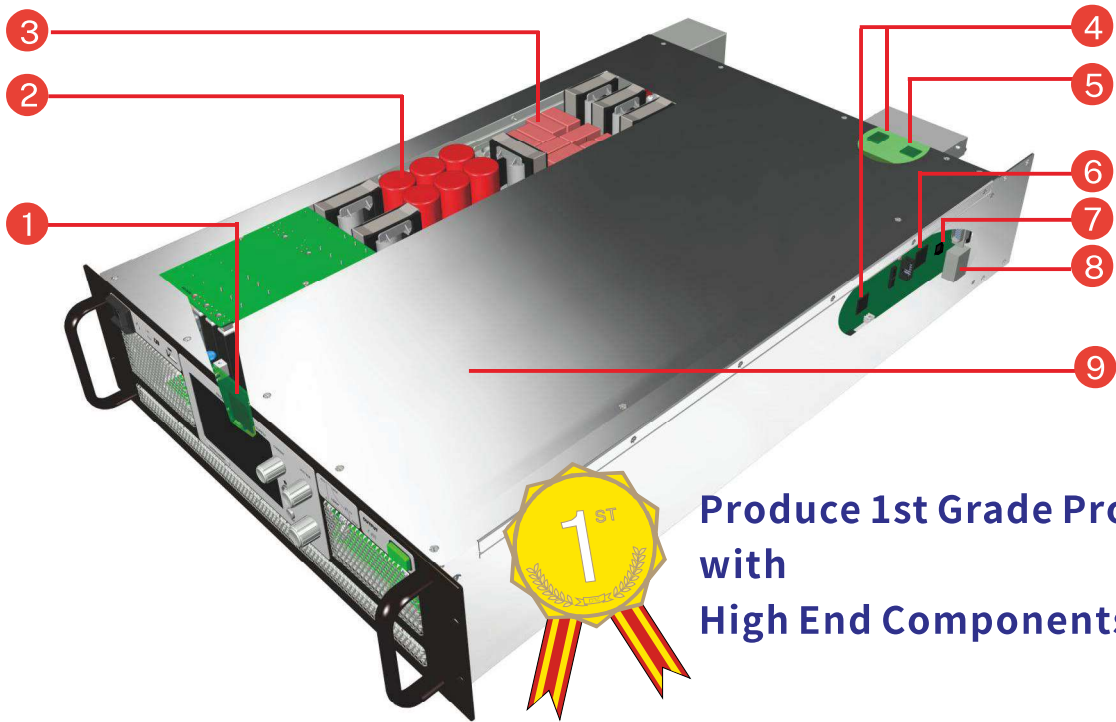

Produce 1st Grade Products with High End Components

**Cortex-A9** 1  
MPU

**Nippon Chemi-Con** 2  
**Electrolytic Capacitors**  
5000 hours of operation at 105°C

**WIMA** 3  
**Polypropylene Capacitors**  
life > 300 k hours

**Cortex-M3** 4  
MCU

**Single-chip IEEE 488.2** 5  
**Talker/Listener interface to the GPIB**

**Cortex-M4** 6  
MCU , Native Ethernet

**CTC : DC to DC** 8

**Pulse : PulseJack** 7  
2 PORT

**Silicon Carbide MOSFET** 9

DSP-WS Series



- Easily and accurately simulate solar array I-V characteristics for evaluating PV inverters. The desired I-V curve can be created via Table Mode or Curve Mode. With Curve Mode, the user needs to set only four parameters using graphical software (available at URL {www.idrc.com.tw/soft/dsp-wx\_app.zip}) or directly input from the front panel. The Table Mode allows users to shape an I-V curve by entering between 3 and 1024 points. The DSP-WS/AS will automatically enhance the resolution to 8000 points to generate a smooth curve.

Voc : Open circuit voltage  
 Vmp : Voltage at maximum power  
 Isc : Short circuit current  
 Imp : Current at maximum power

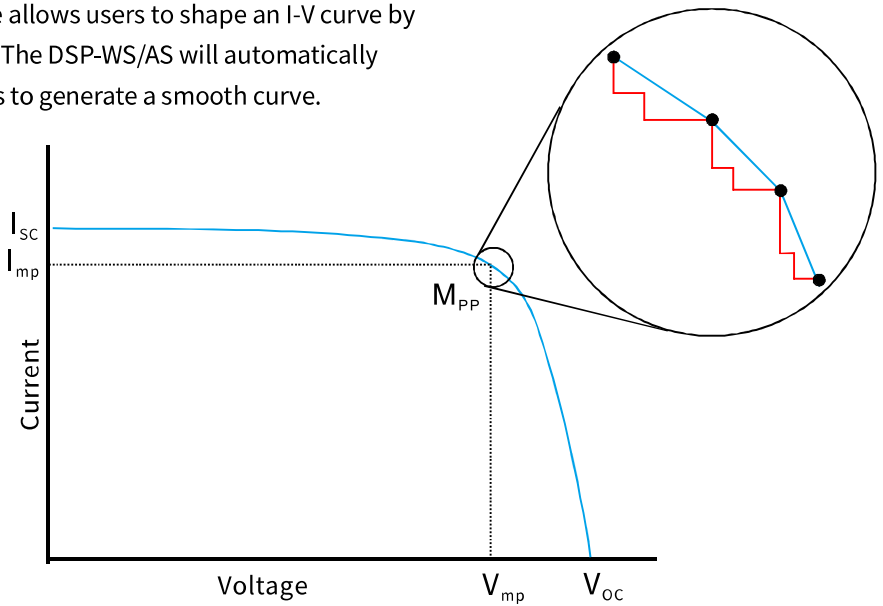

⦿ Solar Array Simulator (DSP-WS / DSP-WAs)

Output Power (11 models)	Models	Max. Voltage	Current @ Max. Voltage	Voltage @ Max. Current	Max. Current
		V1	A1	V2	A2
10kW (3 models)	DSP650-46WS / As	650 V	15.38 A	217.39 V	46 A
	DSP1000-30WS / As	1000 V	10 A	333.33 V	30 A
	DSP1300-23WS / As	1300 V	7.69 A	434.78 V	23 A
12kW (2 models)	DSP1000-36WS / As	1000 V	12 A	333.33 V	36 A
	DSP1300-27WS / As	1300 V	9.23 A	444.44 V	27 A
15kW (4 models)	DSP650-69WS / As	650 V	23.07 A	217.39 V	69 A
	DSP1050-42WS / As	1050 V	14.28 A	357.14 V	42 A
	DSP1500-30WS / As	1500 V	10 A	500 V	30 A
	DSP1950-23WS / As	1950 V	7.69 A	650 V	23 A
18kW (2 models)	DSP1500-36WS / As	1500 V	12 A	500 V	36 A
	DSP1950-27WS / As	1950 V	9.23 A	666.66 V	27 A

## Features

- Imitate the output characteristics of various solar arrays using the built-in solar array simulation function.
- Two input modes (Curve & Table) allow creation of smooth and realistic solar array waveforms.
- Graphic control software meets EN50530 and Sandia requirements.
- Simulations of I-V curves can accommodate changes in temperature and irradiance.
- Static & Dynamic MPPT efficiency test (accumulated energy method) with log files.
- Real-time Maximum Power Point Tracing via remote interface.
- Versatile working modes: I-V curve; constant voltage; constant current; and constant power.
- Desired I-V curve can be downloaded to the WSP-WS series via the LAN interface, or through the USB port.
- Multitasking allows up to 16 controllable Solar Array simulations.
- The WSP-WS series uses an 18-bit DAC for setting and a 24-bit ADC for measuring.

## I/V curve editor screenshot (DSP-WS / DSP-WAs Series)



I/V curve- EN 50530

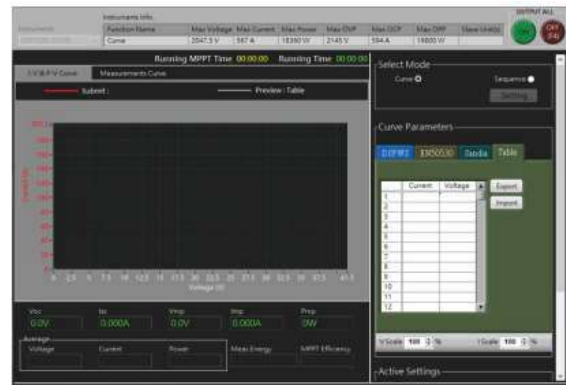

I/V curve- Table mode



I/V curve - Sandia



Max. power point(Pmp)



Shadow mode



Real World Weather



Front Panel

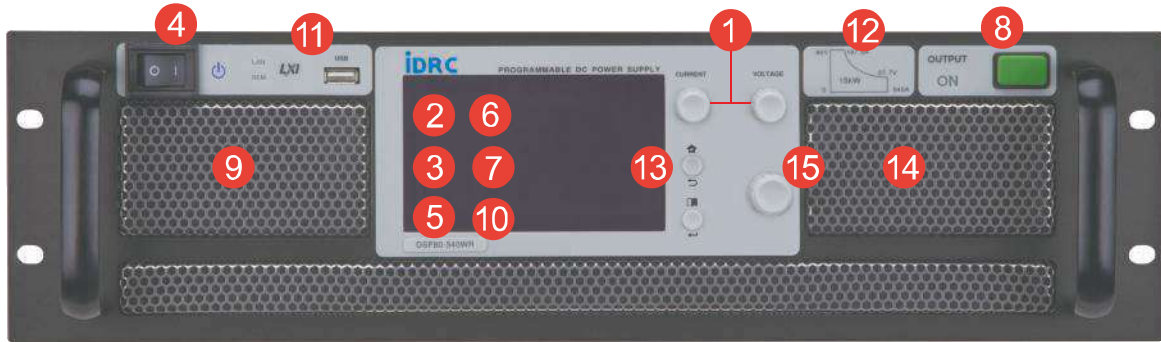

1

Clear, modern control design with individual knobs for current and voltage. Spinning the knob gives rapid and precise setting of values; pushing the knob selects the desired value.

2

Complete Mode: The DSP-Wx series touchscreen (on models with screen) allow users to see and adjust the Voltage, Current, Power, and Time settings. Three memory registers give quick retrieval of commonly-used settings

3

A Simple Mode allows Current and Voltage to be adjusted: power will be automatically set.

4

A robust power switch has a safety guard to prevent accidental operation.

5

ARM Cortex-A9<sup>(note)</sup> graphical microprocessor brings smooth operation and fast response.

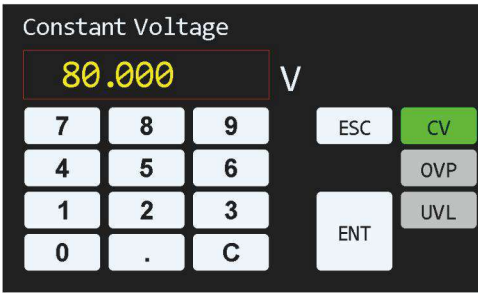
**6** 

Output Voltage, OVP, and UVP settings are all on one screen. Simply enter desired values with the on-screen numeric pad.

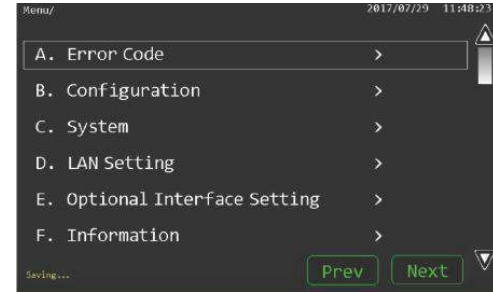
**7** 

Menu selection items are fully spelled out for clarity and ease of use.

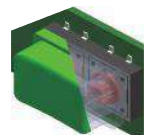
**8** 

Two Internal interlocked switches (patented) provide an extra layer of safety.

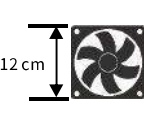
**9** 

Cooling by 12x12 cm speed-controlled fan providing 150 CFM airflow, when needed.

**10** 

High resolution TFT LCD touchscreen (800 x 480) WVGA

**11** 

USB Type A port allows access of USB memory up to 32GB.

**12** 

Label shows the maximum combinative values of voltage and current.

**13** 

HOME key gives rapid access to previous page or hold for 1.5 seconds to return to the Main page.

**14** 

Eco-friendly paintless/non-plated stainless steel hexagonal mesh maximizes ventilation.

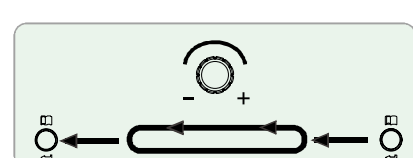
**15** 

Hybrid task-selection knob provides full control of DSP-Wx series functions, duplicating touchscreen controls.

## Remote Control Interface

**6** LXI interface (Standard)



**7** Isolated analog interface (Optional)



**8** GPIB interface (Optional)

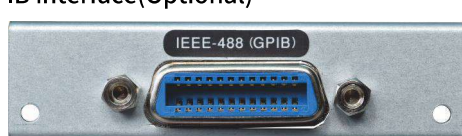

**9** Isolated RS-422 & 485 / USB interface (Optional)



## Rear Panel

- 16 Current sharing
- 17 System IN/OUT
- 18 Digital I/O
- 19 LAN (LXI) connector
- 20 Slot for optional interfaces
- 21 Output terminals and cover
- 22 Remote sense/compensation terminal
- 23 Output terminals
- 24 Output terminals
- 25 Output terminals (80V/10kW & 15kW)
- 26 Output terminals (80V/10kW & 15kW)
- 27 AC input terminals

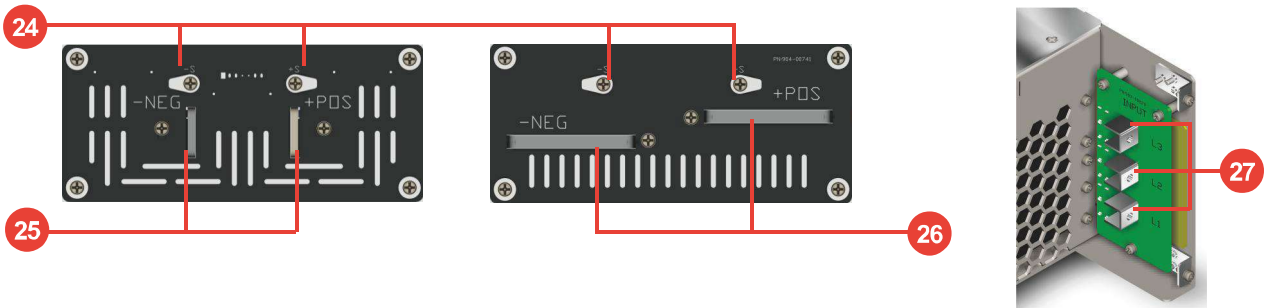
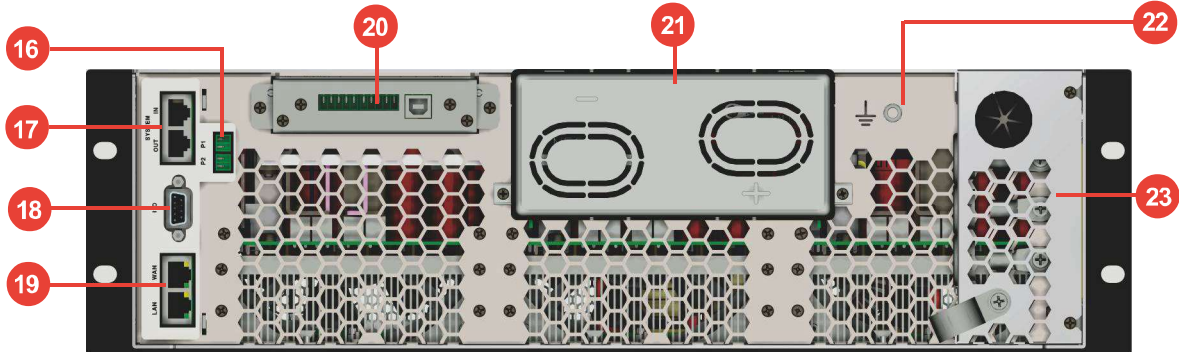

## Dimensions (mm)

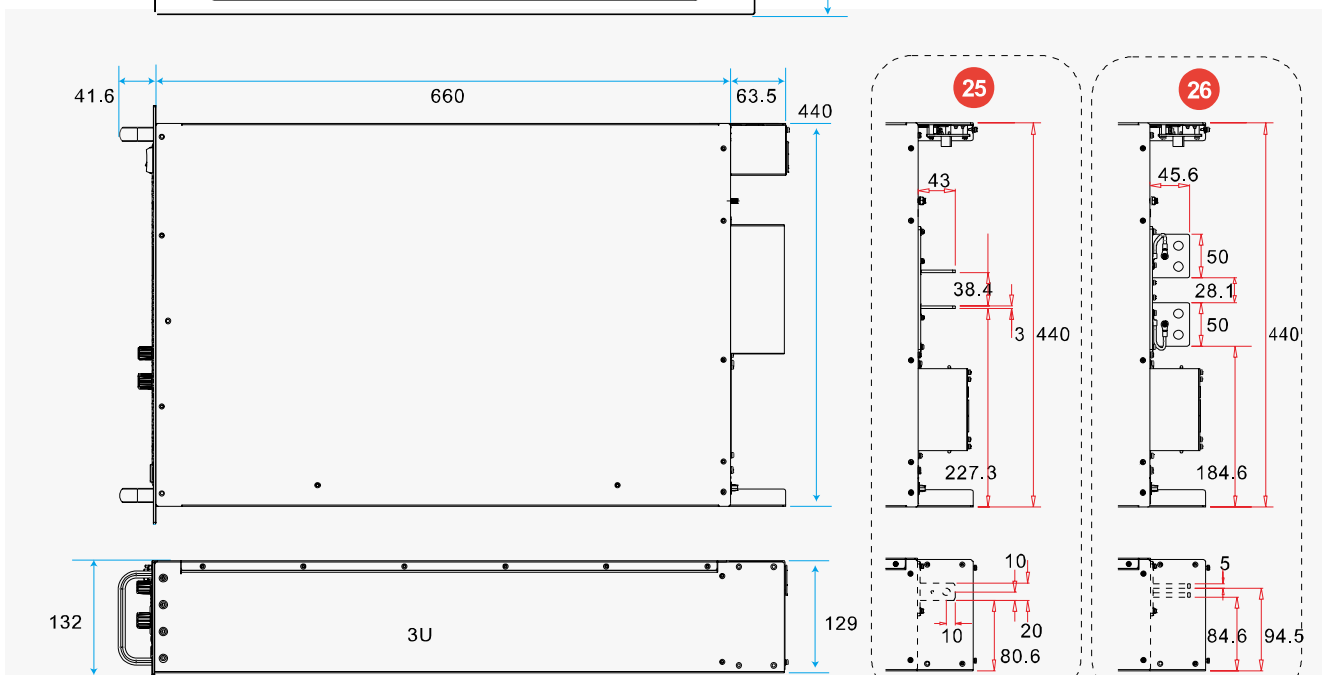
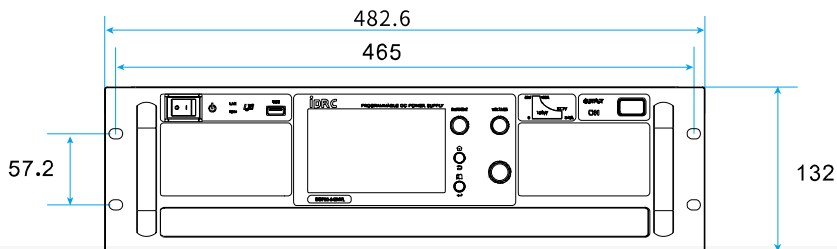

## MAIN / SUBsidiary Configuration

Several configurations of pre-assembled rack with Power Distribution Unit (PDU) are available.

- **Paralleling up to 100 units**  
Up to 1,800kW  
Up to 54,000A (80V model)
- MAIN automatically detects all SUB units.
- Surplus SUB unit(s) can be off to save energy. (\*1)
- Zero gap stacking, superior power density.  
180kW in 30U rack
- Aggregated display  
MAIN unit controls and displays the actual values of entire system.
- Ultra-fast synchronization  
Up to several Mbps of synchronization, extremely low ripple.
- Smart PDU  
Full remote control.  
Sequential power on/off of SUB units.  
Monitoring power quality and power consumption.

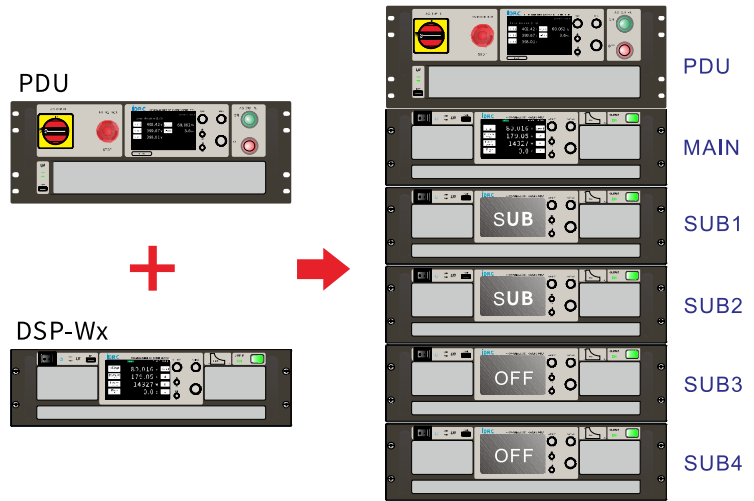

\*1 : Switch Off from the last unit

- **Expand the Power Capacity**  
DSP-Wx and DSP-WAx(blank panel) series Programmable DC Power Supply allows 100 units paralleling to expand the power capacity, with features as follows:
  - 5kW or 10 kW models can be paralleled to form a power system.
  - DSP-WAx series(blank panel) model is able to serve as a MAIN unit
  - Flexible and versatile integration, as shown below:

**Mode 1 : 1 unit of DSP-WR/E(MAIN)  
+ N units of DSP-Wx(SUBsidiary)**  
User can manipulate and have readings on panel or via interface.

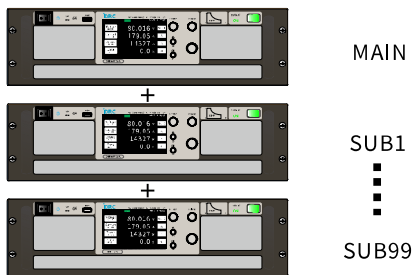

**Mode 3 : 1 unit of DSP-WR/E(MAIN)  
+ N units of DSP-WAx(SUBsidiary)**  
The most typical power system associated by one full function model as the MAIN plus blank panel models, all controls and readings aggregate to MAIN unit.

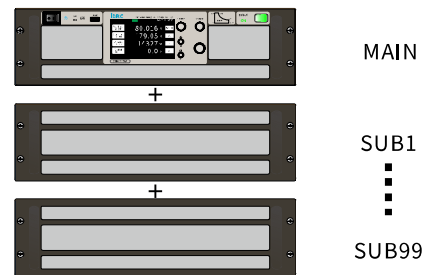

**Mode 2 : 1 unit of DSP-WAx(MAIN)  
+ N units of DSP-WAx(SUBsidiary)**  
The MAIN/SUB setting switch and indicators are behind the intake of DSP-WAx series Programmable DC Power Supply. All operation and display are made by a PC via interface.

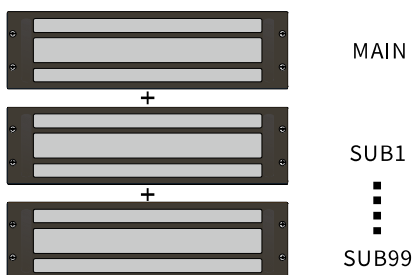

**Mode 4 : 1 unit of DSP-WR/E or DSP-WAx(MAIN)  
+N units of DSP-WR/E or DSP-WAx(SUBsidiary)**  
Any model of the DSP-Wxx series is able to act as a MAIN or SUBsidiary unit. This versatile feature allows users to build integrated power systems of any kind or combination of DSP-Wxx models, as long as they have the same voltage and power ratings.

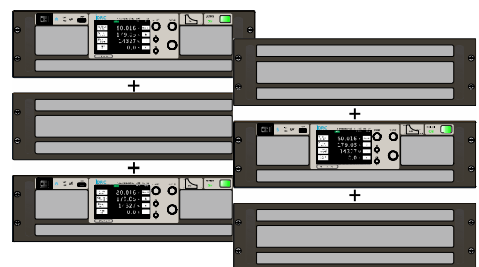

## Application

### Diode, Laser Diode, LED, Power Chip Testing

DSP-Wx series provides CV(Constant Voltage), CC(Constant Current) and CP(Constant Power) modes; users can select the mode suitable to their test requirements.

Below shows an application of CC mode avoiding any current/voltage overshoot during diode validation.

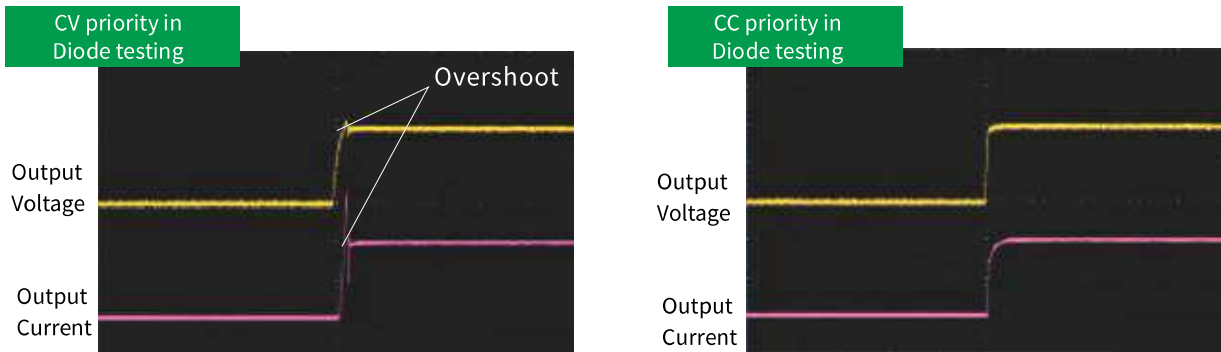

### Lead Acid /Lithium Battery Testing

- iDRC wide range DC Power Supply can adjust output range to fit various battery layouts. The DSP-Wx series reduces the cost of purchasing purpose-built power supplies.
- By using DSP-Wx series DC Power Supply, one unit can reach high voltage/low current and low voltage/high current, significantly reducing the cost and space requirements of test equipment.
- DSP-Wx series Wide Range DC Power Supply with sufficient current and voltage capacity to test batteries in parallel or series.

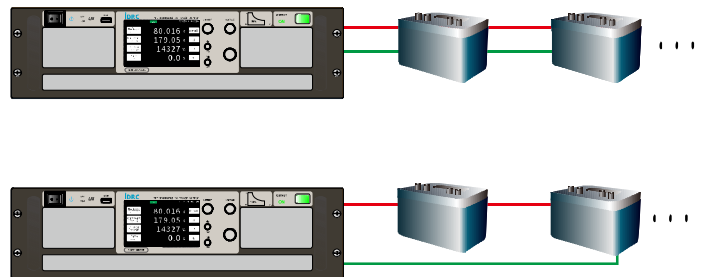

### ATE Integration

- DSP-WA/WAe/WAs series without front panel are suitable for ATE and SUBsidiary unit application.
- Full function design capable of acting as a MAIN unit.
- Equipped with indicators to show operating conditions for convenient visual checks.

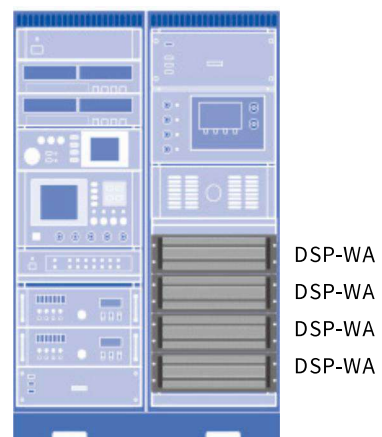
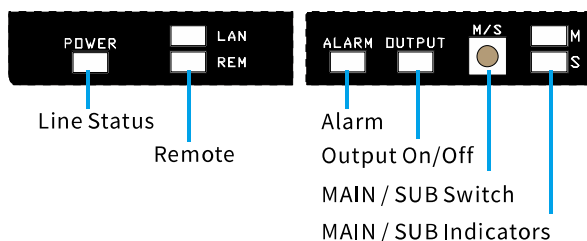

## Application

### Electric/Hybrid Vehicle and General Motor Testing

While electric vehicle design pursues better endurance and energy conversion efficiency, there is an increasing demand for highly flexible and reliable DC power supplies.

The DSP-Wx series DC power supply provides 5kW-1800kW wide-range voltage/current control. They are capable of adjusting to all test scenarios.

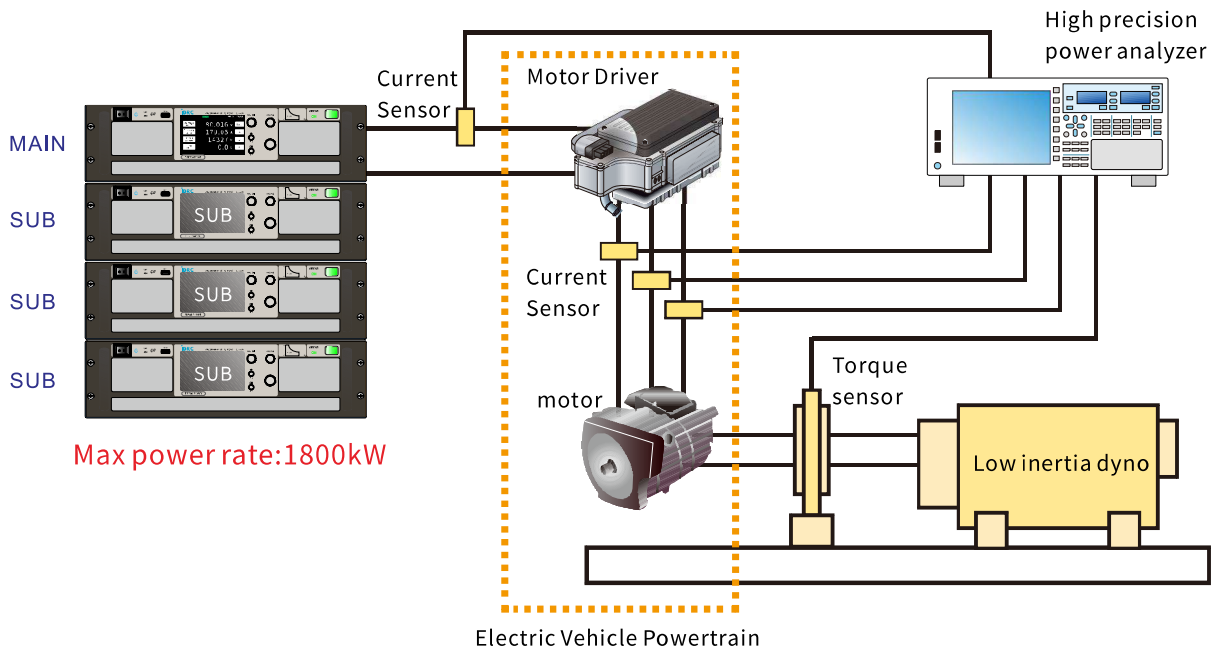

### Power Conditioning of Solar Array and Fuel Cell Testing

The DSP-WS series power supplies simulate the output of solar arrays and fuel cells, making them capable of testing a wide range of products to meet domestic and commercial regulations.

Commercial Solar array Power System voltage rating has improved from 1000V to 2000V.

Higher voltages require less current to achieve the same power rating so new generation solar cell arrays usually have high loop voltages to simplify wiring, reduce capital expenditures and lower running costs.

DSP-WS DC Power Supply 1950V output meets the demand of high voltage testing.

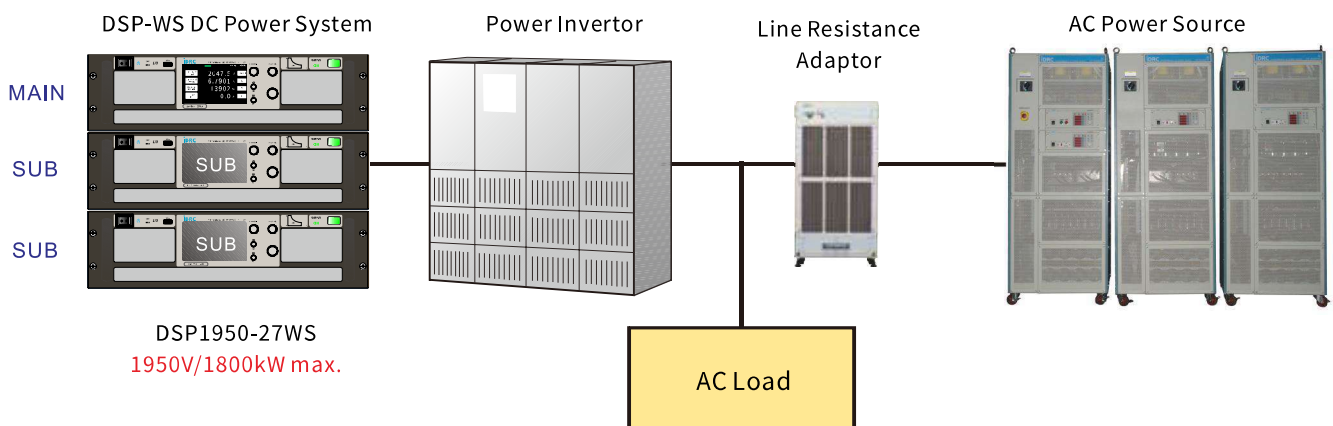

## Interface Support

- Built-in 2 LAN(LXI) ports minimize wiring and reduce network complexity.
- Multi-purposed slot for optional interface, GPIB/Serial Port/Isolated Analog.
- Support interface extension with physical isolation application including:
  - Isolated USB
  - Optical Fiber
  - Wireless LAN



## Wide Range Power Supply versus Conventional Power Supply

This application software is compatible with DSP-WR, DSP-WE, DSP-WS, DSP-WA, DSP-WAs and DSP-WAe Series Wide Range Programmable DC Power Supply.

- Display output characteristic curve.
- Compare power range of Wide Range Model with Conventional Model
- Display value anywhere on the curve.
- Report Printing
- Show off the output value including:
  - Current at maximum power
  - Voltage at maximum power
  - The difference in current

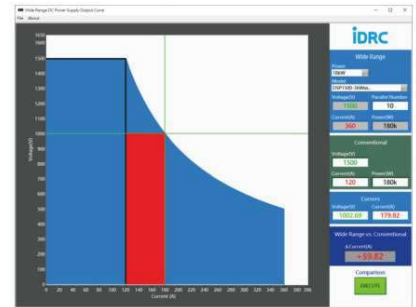

## GUI software

This application software is compatible with DSP-Wx series Wide Range Programmable DC Power Supply. Series Wide Range Programmable DC Power

- Allow to control synchronously up to 16 units of DSP-Wx Series. (\*1) Simulation waveform of output V, C, P..etc.
- Provide 16 sets Sequence Group containing 500 step of each Sequence, and have flexible Loop and Random-linked function setting.
- Provide I-V curve simulation accordance with EN50530, Sandia regulation, and can set up MPPT and recording interval time (\*1).
- Shadow mode have parameter setting incl. cloud moving direction, setup time, and changing time.
- In Real World Weather mode, user can load user-recording file and estimate running time automatically. (\*1)

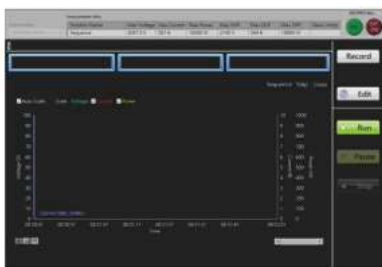

(\*1) functions only for full version, standard version is for trial use.

## DSP-Wx Firmware Update

Update firmware easily with PC and WR-OPT-FUA adaptor.

### RISK FREE

Enhanced safety mechanism to prevent any firmware update failure.



## 5kW ~ 10kW Specifications

Rated Power	5kW	5kW	5kW	5kW	5kW	10kW
Model number	DSP80-180W□□	DSP250-60W□□	DSP350-42W□□	DSP500-30W□□	DSP650-23W□□	DSP80-360W□□
Rated Voltage	80V	250V	350V	500V	650V	80V
Rated Current	180A	60A	42A	30A	23A	360A
<b>Constant Voltage</b>						
Rated value	0~80V	0~250V	0~350V	0~500V	0~650V	0~80V
Settable range(*1)	0~84V	0~262.5V	0~367.5V	0~525V	0~682.5V	0~84V
Over voltage protection (OVP)	0%~110% of rated output voltage					
Voltage @ Max. Current	27.77V	83.33V	119.04V	166.66V	217.39V	27.77V
Programming resolution	5 digits					
Programming accuracy(*2)	±0.1% of rated voltage					
Meter resolution	5 digits					
Meter accuracy(*2)	± 0.1% of rated voltage					
Line regulation(*6)	±0.02% of rated voltage (with local sense)					
Load regulation(*7)	±0.05% of rated voltage (with local sense)					
Temperature coefficient for set values	100ppm/°C of rated output voltage, after a 30 minutes warm-up					
Ripple & noise(*3)(*4)	Vpp					
(with local sense)(CV Mode)	Vrms					
	<180mV	<270mV	<288mV	<315mV	<720mV	<288mV
	<15mV	<36mV	<50mV	<63mV	<180mV	<23mV
Full load up	<30ms					
Full load down	<80ms					
No load down	<5s	<10s	<10s	<5s	<6s	<5s
Transient Response(*5)	<1.5ms					
Remote Compensation	5V					
<b>Constant Current</b>						
Rated value	0~180A	0~60A	0~42A	0~30A	0~23A	0~360A
Settable range(*1)	0~189A	0~63A	0~44.1A	0~31.5A	0~24.15A	0~378A
Over current protection (OCP)	0%~110% of rated output current					
Current @ Max. Voltage	62.5A	20A	14.28A	10A	7.69A	125A
Programming resolution	5 digits					
Programming accuracy(*2)	±0.2% of rated current					
Meter resolution	5 digits					
Meter accuracy(*2)	± 0.2% of rated current					
Line regulation(*6)	±0.05% of rated current					
Load regulation(*7)	±0.15% of rated current					
Temperature coefficient for set values	100ppm/°C of rated output voltage, after a 30 minutes warm-up					
Ripple & noise(*3)(*4)	Arms					
(with local sense)(CC Mode)						
	72mA	20mA	16mA	15mA	15mA	144mA
<b>Constant Power</b>						
Rated value	0~5kW	0~5kW	0~5kW	0~5kW	0~5kW	0~10kW
Settable range(*1)(*8)	0~5100W	0~5100W	0~5100W	0~5100W	0~5100W	0~10200W
Over power protection (OPP)(*8)	0%~110% of rated output current					
Programming resolution(*8)	5 digits					
Programming accuracy(*8)	< 1% of rated power					
Meter resolution	5 digits					
Meter accuracy(*2)	± 0.5% of rated power					
Line regulation(*6)	< 0.05% of rated power					
Load regulation(*7)	< 0.75% of rated power					
<b>Internal resistance(*8)</b>						
Adjustment range	0~0.4444Ω	0~4.1667Ω	0~8.3333Ω	0~16.667Ω	0~28.261Ω	0~0.2222Ω
Programming resolution	0.0001Ω	0.0001Ω	0.0001Ω	0.001Ω	0.001Ω	0.0001Ω
Programming Accuracy(*2)	≤2.3% of max. resistance					
<b>Input</b>						
Nominal input rating	200~415V 50Hz/60Hz 3-phase 3 wires , Optional 480V 50/60Hz 3-phase 4 wires					
Input voltage range	180~460VAC , Optional 480VAC type:432~528VAC					
Input frequency range	47Hz~63Hz					
Current (Maximum)(Input 3P180V)	20A/phase	20A/phase	20A/phase	20A/phase	20A/phase	40A/phase
Inrush current(Input 3P 460V)	33A/phase	33A/phase	33A/phase	33A/phase	33A/phase	66A/phase
Input Power (Maximum)	6kVA	6kVA	6kVA	6kVA	6kVA	12kVA
Efficiency	86~95% varies by model					
Leakage current	< 3.5 mA					
Power Factor	0.99 typ.(480V input) / 0.95 typ.(200~415V input)					
<b>Insulation</b>						
Primary - Chassis	DC 2500V					
Primary - Secondary	DC 2500V					
Secondary - Chassis	DC750V	DC750V	DC750V	DC1000V	DC1500V	DC750V
<b>Weights and dimensions</b>						
Dimensions(WxHxD)	Enclosure : 440 x 129 x 660 mm , Total : 482 x 132 x 765.1 mm					
Weight (kg)	27.5	26	26	26	26	36.3



## 10kW Specifications

Rated Power	10kW	10kW	10kW	10kW	10kW	10kW
Model number	DSP160-180W□□	DSP250-120W□□	DSP350-84W□□	DSP500-60W□□	DSP650-46W□□	DSP1000-30W□□
Rated Voltage	160V	250V	350V	500V	650V	1000V
Rated Current	180A	120A	84A	60A	46A	30A
<b>Constant Voltage</b>						
Rated value	0~160V	0~250V	0~350V	0~500V	0~650V	0~1000V
Settable range(*1)	0~168V	0~262.5V	0~367.5V	0~525V	0~682.5V	0~1050V
Over voltage protection (OVP)	0%~110% of rated output voltage					
Voltage @ Max. Current	55.55V	83.33V	119.04V	166.66V	217.39V	333.33V
Programming resolution	5 digits					
Programming accuracy(*2)	±0.1% of rated voltage					
Meter resolution	5 digits					
Meter accuracy(*2)	± 0.1% of rated voltage					
Line regulation(*6)	±0.02% of rated voltage (with local sense)					
Load regulation(*7)	±0.05% of rated voltage (with local sense)					
Temperature coefficient for set values	100ppm/°C of rated output voltage, after a 30 minutes warm-up					
Ripple & noise(*3)(*4)	Vpp					
(with local sense)(CV Mode)	Arms					
	<432mV	<270mV	<288mV	<315mV	<720mV	<1440mV
	<35mV	<36mV	<50mV	<63mV	<180mV	<315mV
Full load up	<30ms					
Full load down	<80ms					
No load down	<5s	<10s	<10s	<5s	<6s	<10s
Transient Response(*5)	<1.5ms					
Remote Compensation	5V					
<b>Constant Current</b>						
Rated value	0~180A	0~120A	0~84A	0~60A	0~46A	0~30A
Settable range(*1)	0~189A	0~126A	0~88.2A	0~63A	0~48.3A	0~31.5A
Over current protection (OCP)	0%~110% of rated output current					
Current @ Max. Voltage	62.5A	40A	28.57A	20A	15.38A	10A
Programming resolution	5 digits					
Programming accuracy(*2)	±0.2% of rated current					
Meter resolution	5 digits					
Meter accuracy(*2)	± 0.2% of rated current					
Line regulation(*6)	±0.05% of rated current					
Load regulation(*7)	±0.15% of rated current					
Temperature coefficient for set values	100ppm/°C of rated output voltage, after a 30 minutes warm-up					
Ripple & noise(*3)(*4)						
(with local sense)(CC Mode)	Arms					
	72mA	40mA	32mA	29mA	29mA	20mA
<b>Constant Power</b>						
Rated value	0~10kW	0~10kW	0~10kW	0~10kW	0~10kW	0~10kW
Settable range(*1)(*8)	0~10200W	0~10200W	0~10200W	0~10200W	0~10200W	0~10200W
Over power protection (OPP)(*8)	0%~110% of rated output current					
Programming resolution(*8)	5 digits					
Programming accuracy(*8)	< 1% of rated power					
Meter resolution	5 digits					
Meter accuracy(*2)	± 0.5% of rated power					
Line regulation(*6)	< 0.05% of rated power					
Load regulation(*7)	< 0.75% of rated power					
<b>Internal resistance(*8)</b>						
Adjustment range	0~0.8888Ω	0~2.0833Ω	0~4.1667Ω	0~8.3333Ω	0~14.130Ω	0~33.333Ω
Programming resolution	0.0001Ω	0.0001Ω	0.0001Ω	0.0001Ω	0.001Ω	0.001Ω
Programming Accuracy(*2)	≤2.3% of max. resistance					
<b>Input</b>						
Nominal input rating	200~415V 50Hz/60Hz 3-phase 3 wires , Optional 480V 50/60Hz 3-phase 4 wires					
Input voltage range	180~460VAC , Optional 480VAC type:432~528VAC					
Input frequency range	47Hz~63Hz					
Current (Maximum)(Input 3P180V)	40A/phase	40A/phase	40A/phase	40A/phase	40A/phase	40A/phase
Inrush current(Input 3P 460V)	66A/phase	66A/phase	66A/phase	66A/phase	66A/phase	66A/phase
Input Power (Maximum)	12kVA	12kVA	12kVA	12kVA	12kVA	12kVA
Efficiency	86~95% varies by model					
Leakage current	< 3.5 mA					
Power Factor	0.99 typ.(480V input) / 0.95 typ.(200~415V input)					
<b>Insulation</b>						
Primary - Chassis	DC 2500V					
Primary - Secondary	DC 2500V					
Secondary - Chassis	DC750V	DC750V	DC750V	DC1000V	DC1500V	DC1500V
<b>Weights and dimensions</b>						
Dimensions(WxHxD)	Enclosure : 440 x 129 x 660 mm , Total : 482 x 132 x 765.1 mm					
Weight (kg)	36.3	34.8	34.8	34.8	34.8	34.8

## 10kW ~ 15kW Specifications

Rated Power	10kW	15kW	15kW	15kW	15kW	15kW
Model number	DSP1300-23W□□	DSP80-540W□□	DSP250-180W□□	DSP350-126W□□	DSP500-90W□□	DSP650-69W□□
Rated Voltage	1300V	80V	250V	350V	500V	650V
Rated Current	23A	540A	180A	126A	90A	69A
<b>Constant Voltage</b>						
Rated value	0~1300V	0~80V	0~250V	0~350V	0~500V	0~650V
Settable range(*1)	0~1365V	0~84V	0~262.5V	0~367.5V	0~525V	0~682.5V
Over voltage protection (OVP)	0%~110% of rated output voltage					
Voltage @ Max. Current	434.78V	27.77V	83.33V	119.04V	166.66V	217.39V
Programming resolution	5 digits					
Programming accuracy(*2)	±0.1% of rated voltage					
Meter resolution	5 digits					
Meter accuracy(*2)	± 0.1% of rated voltage					
Line regulation(*6)	±0.02% of rated voltage (with local sense)					
Load regulation(*7)	±0.05% of rated voltage (with local sense)					
Temperature coefficient for set values	100ppm/°C of rated output voltage, after a 30 minutes warm-up					
Ripple & noise(*3)(*4)	Vpp	<1800mV	<288mV	<270mV	<288mV	<315mV
(with local sense)(CV Mode)	Vrms	<395mV	<23mV	<36mV	<50mV	<63mV
Full load up	<30ms					
Full load down	<80ms					
No load down	<6s	<5s	<10s	<10s	<5s	<6s
Transient Response(*5)	<1.5ms					
Remote Compensation	5V					
<b>Constant Current</b>						
Rated value	0~23A	0~540A	0~180A	0~126A	0~90A	0~69A
Settable range(*1)	0~24.15A	0~567A	0~189A	0~132.3A	0~94.5A	0~72.45A
Over current protection (OCP)	0%~110% of rated output current					
Current @ Max. Voltage	7.69A	187.5A	60A	42.84A	30A	23.07A
Programming resolution	5 digits					
Programming accuracy(*2)	±0.2% of rated current					
Meter resolution	5 digits					
Meter accuracy(*2)	± 0.2% of rated current					
Line regulation(*6)	±0.05% of rated current					
Load regulation(*7)	±0.15% of rated current					
Temperature coefficient for set values	100ppm/°C of rated output voltage, after a 30 minutes warm-up					
Ripple & noise(*3)(*4)	Arms	20mA	216mA	60mA	45mA	44mA
(with local sense)(CC Mode)						
<b>Constant Power</b>						
Rated value	0~10kW	0~15kW	0~15kW	0~15kW	0~15kW	0~15kW
Settable range(*1)(*8)	0~10200W	0~15300W	0~15300W	0~15300W	0~15300W	0~15300W
Over power protection (OPP)(*8)	0%~110% of rated output current					
Programming resolution(*8)	5 digits					
Programming accuracy(*8)	< 1% of rated power					
Meter resolution	5 digits					
Meter accuracy(*2)	± 0.5% of rated power					
Line regulation(*6)	< 0.05% of rated power					
Load regulation(*7)	< 0.75% of rated power					
<b>Internal resistance(*8)</b>						
Adjustment range	056.521Ω	0~0.1481Ω	0~1.3889Ω	0~2.7778Ω	0~5.5556Ω	0~9.4203Ω
Programming resolution	0.001Ω	0.0001Ω	0.0001Ω	0.0001Ω	0.0001Ω	0.0001Ω
Programming Accuracy(*2)	≤2.3% of max. resistance					
<b>Input</b>						
Nominal input rating	200~415V 50Hz/60Hz 3-phase 3 wires , Optional 480V 50/60Hz 3-phase 4 wires					
Input voltage range	180~460VAC , Optional 480VAC type:432~528VAC					
Input frequency range	47Hz~63Hz					
Current (Maximum)(Input 3P180V)	40A/phase	60A/phase	60A/phase	60A/phase	60A/phase	60A/phase
Inrush current(Input 3P 460V)	66A/phase	99A/phase	99A/phase	99A/phase	99A/phase	99A/phase
Input Power (Maximum)	12kVA	18kVA	18kVA	18kVA	18kVA	18kVA
Efficiency	86~95% varies by model					
Leakage current	< 3.5 mA					
Power Factor	0.99 typ.(480V input) / 0.95 typ.(200~415V input)					
<b>Insulation</b>						
Primary - Chassis	DC 2500V					
Primary - Secondary	DC 2500V					
Secondary - Chassis	DC2000V	DC750V	DC750V	DC750V	DC1000V	DC1500V
<b>Weights and dimensions</b>						
Dimensions(WxHxD)	Enclosure : 440 x 129 x 660 mm , Total : 482 x 132 x 765.1 mm					
Weight (kg)	34.8	45.1	43.6	43.6	43.6	43.6

## 15kW Specifications

Rated Power	15kW	15kW	15kW	15kW		
Model number	DSP750-60W□□	DSP1050-42W□□	DSP1500-30W□□	DSP1950-23W□□		
Rated Voltage	750V	1050V	1500V	1950V		
Rated Current	60A	42A	30A	23A		
<b>Constant Voltage</b>						
Rated value	0~750V	0~1050V	0~1500V	0~1950V		
Settable range(*1)	0~787.5V	0~1102.5V	0~1575V	0~2047.5V		
Over voltage protection (OVP)	0%~110% of rated output voltage					
Voltage @ Max. Current	250V	357.14V	500V	650V		
Programming resolution	5 digits					
Programming accuracy(*2)	±0.1% of rated voltage					
Meter resolution	5 digits					
Meter accuracy(*2)	± 0.1% of rated voltage					
Line regulation(*6)	±0.02% of rated voltage (with local sense)					
Load regulation(*7)	±0.05% of rated voltage (with local sense)					
Temperature coefficient for set values	100ppm/°C of rated output voltage, after a 30 minutes warm-up					
Ripple & noise(*3)(*4)	Vpp	<830mV	<1440mV	<2160mV	<2160mV	
(with local sense)(CV Mode)	Vrms	<196mV	<315mV	<360mV	<510mV	
Full load up	<30ms					
Full load down	<80ms					
No load down	<10s	<10s	<6s	<6s		
Transient Response(*5)	<1.5ms					
Remote Compensation	5V					
<b>Constant Current</b>						
Rated value	0~60A	0~42A	0~30A	0~23A		
Settable range(*1)	0~63A	0~44.1A	0~31.5A	0~24.15A		
Over current protection (OCP)	0%~110% of rated output current					
Current @ Max. Voltage	20A	14.29A	10A	7.69A		
Programming resolution	5 digits					
Programming accuracy(*2)	±0.2% of rated current					
Meter resolution	5 digits					
Meter accuracy(*2)	± 0.2% of rated current					
Line regulation(*6)	±0.05% of rated current					
Load regulation(*7)	±0.15% of rated current					
Temperature coefficient for set values	100ppm/°C of rated output voltage, after a 30 minutes warm-up					
Ripple & noise(*3)(*4)	Arms	40mA	32mA	24mA	44mA	
(with local sense)(CC Mode)						
<b>Constant Power</b>						
Rated value	0~15kW	0~15kW	0~15kW	0~15kW		
Settable range(*1)(*8)	0~15300W	0~15300W	0~15300W	0~15300W		
Over power protection (OPP)(*8)	0%~110% of rated output current					
Programming resolution(*8)	5 digits					
Programming accuracy(*8)	< 1% of rated power					
Meter resolution	5 digits					
Meter accuracy(*2)	± 0.5% of rated power					
Line regulation(*6)	< 0.05% of rated power					
Load regulation(*7)	< 0.75% of rated power					
<b>Internal resistance</b>						
Adjustment range	0~12.500Ω	0~25.000Ω	0~50.000Ω	0~84.782Ω		
Programming resolution	0.001Ω	0.001Ω	0.001Ω	0.001Ω		
Programming Accuracy(*2)	≤2.3% of max. resistance					
<b>Input</b>						
Nominal input rating	200~415V 50Hz/60Hz 3-phase 3 wires , Optional 480V 50/60Hz 3-phase 4 wires					
Input voltage range	180~460VAC , Optional 480VAC type:432~528VAC					
Input frequency range	47Hz~63Hz					
Current (Maximum)(Input 3P180V)	60A/phase	60A/phase	60A/phase	60A/phase		
Inrush current(Input 3P 460V)	99A/phase	99A/phase	99A/phase	99A/phase		
Input Power (Maximum)	18kVA	18kVA	18kVA	18kVA		
Efficiency	86~95% varies by model					
Leakage current	< 3.5 mA					
Power Factor	0.99 typ.(480V input) / 0.95 typ.(200~415V input)					
<b>Insulation</b>						
Primary - Chassis	DC 2500V					
Primary - Secondary	DC 2500V					
Secondary - Chassis	DC1500V	DC1500V	DC1500V	DC3000V		
<b>Weights and dimensions</b>						
Dimensions(WxHxD)	Enclosure : 440 x 129 x 660 mm , Total : 482 x 132 x 765.1 mm					
Weight (kg)	43.6	43.6	43.6	43.6		

## 6kW ~ 12kW Specifications

Rated Power	6kW	6kW	12kW	12kW	12kW	12kW
Model number	DSP500-36W□□	DSP650-27W□□	DSP500-72W□□	DSP650-54W□□	DSP1000-30W□□	DSP1300-27W□□
Rated Voltage	500V	650V	500V	650V	1000V	1300V
Rated Current	36A	27A	72A	54A	30A	27A
<b>Constant Voltage</b>						
Rated value	0~500V	0~650V	0~500V	0~650V	0~1000V	0~1300V
Settable range(*1)	0~525V	0~682.5V	0~525V	0~682.5V	0~1050V	0~1365V
Over voltage protection (OVP)	0%~110% of rated output voltage					
Voltage @ Max. Current	166.66V	222.22V	166.66V	222.22V	333.33V	444.44V
Programming resolution	5 digits					
Programming accuracy(*2)	±0.1% of rated voltage					
Meter resolution	5 digits					
Meter accuracy(*2)	± 0.1% of rated voltage					
Line regulation(*6)	±0.02% of rated voltage (with local sense)					
Load regulation(*7)	±0.05% of rated voltage (with local sense)					
Temperature coefficient for set values	100ppm/°C of rated output voltage, after a 30 minutes warm-up					
Ripple & noise(*3)(*4) Vpp	<375mV	<864mV	<375mV	<864mV	<1725mV	<2240mV
(with local sense)(CV Mode) Vrms	<75mV	<216mV	<75mV	<216mV	<376mV	<490mV
Full load up	<30ms					
Full load down	<80ms					
No load down	<5s	<6s	<5s	<6s	<5s	<6s
Transient Response(*5)	<1.5ms					
Remote Compensation	5V					
<b>Constant Current</b>						
Rated value	0~36A	0~27A	0~72A	0~54A	0~36A	0~27A
Settable range(*1)	0~37.8A	0~28.35A	0~75.6A	0~56.7A	0~37.8A	0~28.35A
Over current protection (OCP)	0%~110% of rated output current					
Current @ Max. Voltage	12A	9.23A	24A	18.46A	12A	9.23A
Programming resolution	5 digits					
Programming accuracy(*2)	±0.2% of rated current					
Meter resolution	5 digits					
Meter accuracy(*2)	± 0.2% of rated current					
Line regulation(*6)	±0.05% of rated current					
Load regulation(*7)	±0.15% of rated current					
Temperature coefficient for set values	100ppm/°C of rated output voltage, after a 30 minutes warm-up					
Ripple & noise(*3)(*4) Arms	18mA	18mA	35mA	35mA	24mA	24mA
(with local sense)(CC Mode)						
<b>Constant Power</b>						
Rated value	0~6kW	0~6kW	0~12kW	0~12kW	0~12kW	0~12kW
Settable range(*1)(*8)	0~6120W	0~6120W	0~12240W	0~12240W	0~12240W	0~12240W
Over power protection (OPP)(*8)	0%~110% of rated output current					
Programming resolution(*8)	5 digits					
Programming accuracy(*8)	< 1% of rated power					
Meter resolution	5 digits					
Meter accuracy(*2)	± 0.5% of rated power					
Line regulation(*6)	< 0.05% of rated power					
Load regulation(*7)	< 0.75% of rated power					
<b>Internal resistance(*8)</b>						
Adjustment range	0~13.888Ω	0~24.074Ω	0~6.9444Ω	0~12.037Ω	0~27.777Ω	0~48.148Ω
Programming resolution	0.001Ω	0.001Ω	0.0001Ω	0.001Ω	0.001Ω	0.001Ω
Programming Accuracy(*2)	≤2.3% of max. resistance					
<b>Input</b>						
Nominal input rating	380~415V 50Hz/60Hz 3-phase 3 wires					
Input voltage range	340~460VAC					
Input frequency range	47Hz~63Hz					
Current (Maximum)(Input 3P180V)	13A/phase	13A/phase	26A/phase	26A/phase	26A/phase	26A/phase
Inrush current(Input 3P 460V)	33A/phase	33A/phase	66A/phase	66A/phase	66A/phase	66A/phase
Input Power (Maximum)	7.2kVA	7.2kVA	14.4kVA	14.4kVA	14.4kVA	14.4kVA
Efficiency	86~95% varies by model					
Leakage current	< 3.5 mA					
Power Factor	0.95 typ.(380~415V input)					
<b>Insulation</b>						
Primary - Chassis	DC 2500V					
Primary - Secondary	DC 2500V					
Secondary - Chassis	DC1000V	DC1500V	DC1500V	DC1500V	DC1500V	DC2000V
<b>Weights and dimensions</b>						
Dimensions(WxHxD)	Enclosure : 440 x 129 x 660 mm , Total : 482 x 132 x 765.1 mm					
Weight (kg)	26	26	34.8	34.8	34.8	34.8

## 18kW Specifications

Rated Power	18kW	18kW	18kW	18kW		
Model number	DSP500-108W□□	DSP650-81W□□	DSP1500-36W□□	DSP1950-27W□□		
Rated Voltage	500V	650V	1500V	1950V		
Rated Current	108A	81A	36A	27A		
<b>Constant Voltage</b>						
Rated value	0~500V	0~650V	0~1500V	0~1950V		
Settable range(*1)	0~525V	0~682.5V	0~1575V	0~2047.5V		
Over voltage protection (OVP)	0%~110% of rated output voltage					
Voltage @ Max. Current	166.66V	222.22V	500V	666.66V		
Programming resolution	5 digits					
Programming accuracy(*2)	±0.1% of rated voltage					
Meter resolution	5 digits					
Meter accuracy(*2)	± 0.1% of rated voltage					
Line regulation(*6)	±0.02% of rated voltage (with local sense)					
Load regulation(*7)	±0.05% of rated voltage (with local sense)					
Temperature coefficient for set values	100ppm/°C of rated output voltage, after a 30 minutes warm-up					
Ripple & noise(*3)(*4)	Vpp					
(with local sense)(CV Mode)	Arms					
	<375mV	<864mV	<2590mV	<3360mV		
	<75mV	<216mV	<430mV	<645mV		
Full load up	<30ms					
Full load down	<80ms					
No load down	<5s	<6s	<6s	<6s		
Transient Response(*5)	<1.5ms					
Remote Compensation	5V					
<b>Constant Current</b>						
Rated value	0~108A	0~81A	0~36A	0~27A		
Settable range(*1)	0~113.4A	0~85.05A	0~37.8A	0~28.35A		
Over current protection (OCP)	0%~110% of rated output current					
Current @ Max. Voltage	36A	27.69A	12A	9.23A		
Programming resolution	5 digits					
Programming accuracy(*2)	±0.2% of rated current					
Meter resolution	5 digits					
Meter accuracy(*2)	± 0.2% of rated current					
Line regulation(*6)	±0.05% of rated current					
Load regulation(*7)	±0.15% of rated current					
Temperature coefficient for set values	100ppm/°C of rated output voltage, after a 30 minutes warm-up					
Ripple & noise(*3)(*4)	Arms					
(with local sense)(CC Mode)	54mA	50mA	42mA	42mA		
<b>Constant Power</b>						
Rated value	0~18kW	0~18kW	0~18kW	0~18kW		
Settable range(*1)(*8)	0~18360W	0~18360W	0~18360W	0~18360W		
Over power protection (OPP)(*8)	0%~110% of rated output current					
Programming resolution(*8)	5 digits					
Programming accuracy(*8)	< 1% of rated power					
Meter resolution	5 digits					
Meter accuracy(*2)	± 0.5% of rated power					
Line regulation(*6)	< 0.05% of rated power					
Load regulation(*7)	< 0.75% of rated power					
<b>Internal resistance(*8)</b>						
Adjustment range	0~4.6296Ω	0~8.0246Ω	0~41.666Ω	0~72.222Ω		
Programming resolution	0.0001Ω	0.0001Ω	0.001Ω	0.001Ω		
Programming Accuracy(*2)	≤2.3% of max. resistance					
<b>Input</b>						
Nominal input rating	380~415V 50Hz/60Hz 3-phase 3 wires					
Input voltage range	340~460VAC					
Input frequency range	47Hz~63Hz					
Current (Maximum)(Input 3P180V)	40A/phase	40A/phase	40A/phase	40A/phase		
Inrush current(Input 3P 460V)	99A/phase	99A/phase	99A/phase	99A/phase		
Input Power (Maximum)	21.6kVA	21.6kVA	21.6kVA	21.6kVA		
Efficiency	86~95% varies by model					
Leakage current	< 3.5 mA					
Power Factor	0.95 typ.(380~415V input)					
<b>Insulation</b>						
Primary - Chassis	DC 2500V					
Primary - Secondary	DC 2500V					
Secondary - Chassis	DC1000V	DC1500V	DC2000V	DC3000V		
<b>Weights and dimensions</b>						
Dimensions(WxHxD)	Enclosure : 440 x 129 x 660 mm , Total : 482 x 132 x 765.1 mm					
Weight (kg)	43.6	43.6	43.6	43.6		

## 10 ~ 15kW(3U) Specifications

Rated Power	10kW	10kW	15kW	15kW	15kW	
Model number	DSP1000-30W□□	DSP1300-23W□□	DSP1050-42W□□	DSP1500-30W□□	DSP1950-23W□□	
Rated Voltage	1000V	1300V	1050V	1500V	1950V	
Rated Current	30A	23A	42A	30A	23A	
<b>Constant Voltage</b>						
Rated value	0~1000V	0~1300V	0~1050V	0~1500V	0~1950V	
Settable range(*1)	0~1050V	0~1365V	0~1102.5V	0~1575V	0~2047.5V	
Over voltage protection (OVP)	0%~110% of rated output voltage					
Voltage @ Max. Current	333.33V	434.78V	357.14V	500V	650V	
Programming resolution	5 digits					
Programming accuracy(*2)	±0.1% of rated voltage					
Meter resolution	5 digits					
Meter accuracy(*2)	± 0.1% of rated voltage					
Line regulation(*6)	±0.02% of rated voltage (with local sense)					
Load regulation(*7)	±0.05% of rated voltage (with local sense)					
Temperature coefficient for set values	100ppm/°C of rated output voltage, after a 30 minutes warm-up					
Ripple & noise(*3)(*4)	Vpp	<1440mV	<1800mV	<1440mV	<2160mV	<2160mV
(with local sense)(CV Mode)	Vrms	<315mV	<395mV	<315mV	<360mV	<510mV
Full load up	<30ms					
Full load down	<80ms					
No load down	<10s	<6s	<10s	<6s	<6s	
Transient Response(*5)	<1.5ms					
Remote Compensation	5V					
<b>Constant Current</b>						
Rated value	0~30A	0~23A	0~42A	0~30A	0~23A	
Settable range(*1)	0~31.5A	0~24.15A	0~44.1A	0~31.5A	0~24.15A	
Over current protection (OCP)	0%~110% of rated output current					
Current @ Max. Voltage	10A	7.69A	14.29A	10A	7.69A	
Programming resolution	5 digits					
Programming accuracy(*2)	±0.2% of rated current					
Meter resolution	5 digits					
Meter accuracy(*2)	± 0.2% of rated current					
Line regulation(*6)	±0.05% of rated current					
Load regulation(*7)	±0.15% of rated current					
Temperature coefficient for set values	100ppm/°C of rated output voltage, after a 30 minutes warm-up					
Ripple & noise(*3)(*4)	Arms	20mA	20mA	32mA	24mA	44mA
(with local sense)(CC Mode)						
<b>Constant Power</b>						
Rated value	0~10kW	0~10kW	0~15kW	0~15kW	0~15kW	
Settable range(*1)(*8)	0~10200W	0~10200W	0~15300W	0~15300W	0~15300W	
Over power protection (OPP)(*8)	0%~110% of rated output current					
Programming resolution(*8)	5 digits					
Programming accuracy(*8)	< 1% of rated power					
Meter resolution	5 digits					
Meter accuracy(*2)	± 0.5% of rated power					
Line regulation(*6)	< 0.05% of rated power					
Load regulation(*7)	< 0.75% of rated power					
<b>Internal resistance(*8)</b>						
Adjustment range	0~33.333Ω	0~56.521Ω	0~25.000Ω	0~50.000Ω	0~84.782Ω	
Programming resolution	0.001Ω	0.001Ω	0.001Ω	0.001Ω	0.001Ω	
Programming Accuracy(*2)	≤2.3% of max. resistance					
<b>Input</b>						
Nominal input rating	200~415V 50Hz/60Hz 3-phase 3 wires , Optional 480V 50/60Hz 3-phase 4 wires					
Input voltage range	180~460VAC , Optional 480VAC type:432~528VAC					
Input frequency range	47Hz~63Hz					
Current (Maximum)(Input 3P180V)	40A/phase	40A/phase	60A/phase	60A/phase	60A/phase	
Inrush current(Input 3P 460V)	66A/phase	66A/phase	99A/phase	99A/phase	99A/phase	
Input Power (Maximum)	12kVA	12kVA	18kVA	18kVA	18kVA	
Efficiency	86~95% varies by model					
Leakage current	< 3.5 mA					
Power Factor	0.99 typ.(480V input) / 0.95 typ.(200~415V input)					
<b>Insulation</b>						
Primary - Chassis	DC 2500V					
Primary - Secondary	DC 2500V					
Secondary - Chassis	DC1500V	DC2000V	DC1500V	DC1500V	DC3000V	
<b>Weights and dimensions</b>						
Dimensions(WxHxD)	Enclosure : 440 x 129 x 660 mm , Total : 482 x 132 x 765.1 mm					
Weight (kg)	34.8	34.8	43.6	43.6	43.6	

## 12 ~ 18kW(3U) Specifications

Rated Power	12kW	12kW	18kW	18kW		
Model number	DSP1000-30W□□	DSP1300-27W□□	DSP1500-36W□□	DSP1950-27W□□		
Rated Voltage	1000V	1300V	1500V	1950V		
Rated Current	30A	27A	36A	27A		
<b>Constant Voltage</b>						
Rated value	0~1000V	0~1300V	0~1500V	0~1950V		
Settable range(*1)	0~1050V	0~1365V	0~1575V	0~2047.5V		
Over voltage protection (OVP)	0%~110% of rated output voltage					
Voltage @ Max. Current	333.33V	444.44V	500V	666.66V		
Programming resolution	5 digits					
Programming accuracy(*2)	±0.1% of rated voltage					
Meter resolution	5 digits					
Meter accuracy(*2)	± 0.1% of rated voltage					
Line regulation(*6)	±0.02% of rated voltage (with local sense)					
Load regulation(*7)	±0.05% of rated voltage (with local sense)					
Temperature coefficient for set values	100ppm/°C of rated output voltage, after a 30 minutes warm-up					
Ripple & noise(*3)(*4)	Vpp					
(with local sense)(CV Mode)	Arms					
	<1725mV	<2240mV	<2590mV	<3360mV		
	<376mV	<490mV	<430mV	<645mV		
Full load up	<30ms					
Full load down	<80ms					
No load down	<5s	<6s	<6s	<6s		
Transient Response(*5)	<1.5ms					
Remote Compensation	5V					
<b>Constant Current</b>						
Rated value	0~36A	0~27A	0~36A	0~27A		
Settable range(*1)	0~37.8A	0~28.35A	0~37.8A	0~28.35A		
Over current protection (OCP)	0%~110% of rated output current					
Current @ Max. Voltage	12A	9.23A	12A	9.23A		
Programming resolution	5 digits					
Programming accuracy(*2)	±0.2% of rated current					
Meter resolution	5 digits					
Meter accuracy(*2)	± 0.2% of rated current					
Line regulation(*6)	±0.05% of rated current					
Load regulation(*7)	±0.15% of rated current					
Temperature coefficient for set values	100ppm/°C of rated output voltage, after a 30 minutes warm-up					
Ripple & noise(*3)(*4)	Arms					
(with local sense)(CC Mode)						
	24mA	24mA	42mA	42mA		
<b>Constant Power</b>						
Rated value	0~12kW	0~12kW	0~18kW	0~18kW		
Settable range(*1)(*8)	0~12240W	0~12240W	0~18360W	0~18360W		
Over power protection (OPP)(*8)	0%~110% of rated output current					
Programming resolution(*8)	5 digits					
Programming accuracy(*8)	< 1% of rated power					
Meter resolution	5 digits					
Meter accuracy(*2)	± 0.5% of rated power					
Line regulation(*6)	< 0.05% of rated power					
Load regulation(*7)	< 0.75% of rated power					
<b>Internal resistance(*8)</b>						
Adjustment range	0~27.777Ω	0~48.148Ω	0~41.666Ω	0~72.222Ω		
Programming resolution	0.001Ω	0.001Ω	0.001Ω	0.001Ω		
Programming Accuracy(*2)	≤2.3% of max. resistance					
<b>Input</b>						
Nominal input rating	380~415V 50Hz/60Hz 3-phase 3 wires					
Input voltage range	340~460VAC					
Input frequency range	47Hz~63Hz					
Current (Maximum)(Input 3P180V)	26A/phase	26A/phase	40A/phase	40A/phase		
Inrush current(Input 3P 460V)	66A/phase	66A/phase	99A/phase	99A/phase		
Input Power (Maximum)	14.4kVA	14.4kVA	21.6kVA	21.6kVA		
Efficiency	86~95% varies by model					
Leakage current	< 3.5 mA					
Power Factor	0.95 typ.(380~415V input)					
<b>Insulation</b>						
Primary - Chassis	DC 2500V					
Primary - Secondary	DC 2500V					
Secondary - Chassis	DC1500V	DC2000V	DC2000V	DC3000V		
<b>Weights and dimensions</b>						
Dimensions(WxHxD)	Enclosure : 440 x 129 x 660 mm , Total : 482 x 132 x 765.1 mm					
Weight (kg)	34.8	34.8	43.6	43.6		

## General Specifications

Environment	
Operating environment	Indoor use
Operating temperature / humidity	0°C ~ 50°C , 30%rh ~ 80%rh (no condensation)
Storage temperature / humidity	-20°C ~ 70°C , 10%RH ~ 80%RH (no condensation)
Altitude	Up to 2000m
Cooling method	Forced air cooling using the speed controlled fan
Ground polarity	Capable of Negative ground or Positive ground
Memory & Sequence	
Number of memory	3 sets (operating in front panel)
Maximum step number	500 steps per each Sequence
Maximum Sequence number	16
Step time settable range	0.00 sec ~ 999999.99 sec
Standard Interface	
LAN interface	LXI 1.4
Digital I/O	Input : Interlock , Output ON/OFF , SHUT OFF Output : Alarm signal , Output voltage downward signal
Optional GPIB Interface	
Compliant	SCPI - 1990, IEEE 488.2 compliant interface;
Optional RS422/RS485 Interface	
Baud Rate	Support 4800 , 9600 , 19200 , 38400 , 57600 , 115200 bps
Optional USB Interface(USB type B connector)	
Compliant	Full Compliant with USB V2.0 specification
Optional Analog Interface	
Status output (dry contact)	CV State , CC State , CP State(*9) , CR State(*9) , ON/OFF State
V control range & accuracy(*2)	0% ~ 100% of rated output voltage in the range of 0V ~ 5V or 0V ~ 10V ; $\pm 0.2\%$
A control range & accuracy(*2)	0% ~ 100% of rated output current in the range of 0V ~ 5V or 0V ~ 10V ; $\pm 0.2\%$
P control range & accuracy(*2,*9)	0% ~ 100% of rated output current in the range of 0V ~ 5V or 0V ~ 10V ; $\pm 0.2\%$
Monitoring output & accuracy(*2)	0~5V or 0~10V output for monitoring V/A/W ; $\pm 2\%$
Reference output	0~5VDC or 0~10VDC (max=5mA)

### Notes:

- \*1) The output voltage and current ranges can be set to 105% of the rated value, but the total output will be less. The extra capacity is used to compensate for external wiring loss and cannot be used as a regular value.
- \*2) Measured at room temperature of  $23 \pm 5^\circ\text{C}$ .
- \*3) rms value of ripple & noise was measured at meter bandwidth 300kHz
- \*4) Peak value of ripple & noise was measured at meter bandwidth 20MHz.
- \*5) The time for the output voltage to reach  $\pm 1\%$  of the setting value at 10% - 90% of rated voltage, and 10% and above of rated power, with a resistance load. (Fig. 1)
- \*6) Input voltage variation between 180~264VAC or 342~460VAC with a fixed loading 1~100%.
- \*7) CV Mode: Constant line voltage; output current variation between 10% - 90% of the rated value.  
CC Mode: Constant line voltage; output voltage variation between 10% - 90% of the rated value.  
CP Mode: Constant line voltage; output voltage\*current variation between 10% - 90% of the rated value.
- \*8) DSP-WE/WAe series are not supported.

### General Remarks:

- a) All data were measured at the output terminal with local sensing, at 2% - 100% of rated voltage, 1% - 100% of rated current, after 30 minutes warm-up, in a room at  $50^\circ\text{C}$  and 80% RH.
- b) "Rise Time" means the time from 10% to 90% of rated voltage; "Fall Time" is the time to drop from 90% to 10% of rated voltage.
- c) The performance will be affected the character of the external wiring for multi-unit paralleling.
- d) LXI interface with minimum 3ms response time. The actual response time will be affected by your network's connection quality and LAN speed.
- e) The information in this document is subject to change without notice and should not be construed as a commitment by iDRC. iDRC assumes no responsibility for any errors that may appear in this document. In no event shall iDRC be liable for incidental or consequential damages arising from use of this document or the software or hardware described in this document.

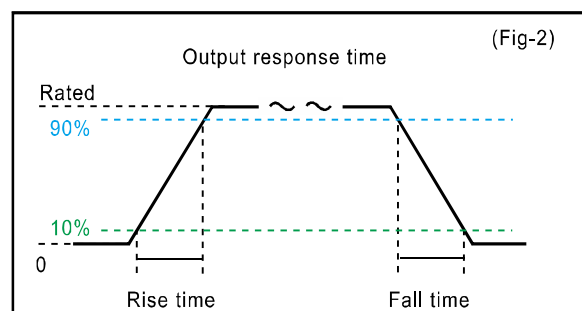
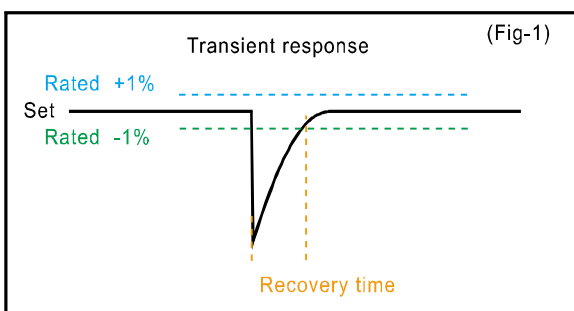



## Programmable Power Distribution Unit series

### PDU10 / PDU6 Programmable Power Distribution Unit

Innovative, patented design and functions. Equipped with digital controller, protection, remote measurement, and multiple connections in parallel, it sequentially controls and secures AC mains supply to the DC power supplies, and provides useful CO<sup>2</sup>e and efficiency readings.

To remain eco-friendly, the PDU series maintains iDRC's stainless steel chassis with very little paint and no plating. The PDU series state-of-the-art functions allow you to manage very high power easily and environmentally.



### World First Innovation

- PDU10/PDU6, 4U height, connect with 10/6 units 18kW iDRC DC power supply.
- MAIN / SUBSidiary function, control millions of watts of DC power via a single LAN cable.
- A 5" 800x480 WVGA touchscreen supplemented with physical controls, forms an intuitive control interface.
- A built-in AC mains monitoring system provides ten or more useful reporting parameters such as V, A, Freq, VA, Watt, VAR, kWh, CO2e and Efficiency.
- Permanent and resettable Time accumulators.
- CE approved.
- LXI 1.5 approved

### Electrical

- 3Ø180~460VAC, 47~63Hz Universal Input.
- Embedded system with multiple 32 bit ARM based MCU, fast boot time of 10 seconds or less.
- Built-in timer allows the setting of output running time.
- Built-in RTC maintains reliable time without a time server.
- Closed-case firmware upgrading and enhanced protection to prevent upgrade failures.
- Full remote control via a single LAN cable.
- Definable Power On to a select-able number of SUB units with the surplus SUB units off to save energy.
- Easy to replace individual output terminal.

## ○ Safety

- SEMATECH std. EMO button- physically off all managed DC power supplies at once.
- Distinct AC output On/Off button, sequence On/Off DC power supplies.
- Lockable power switch to avoid accidental operation.
- Interlock function.

## ○ Interface

- Built-in 2 LAN(LXI) ports, saves the cost of an extra switch hub.
- Fast LAN response time of 3ms.
- SCPI compatible
- Alarm signal output and interlock mechanism prevent potential injury.
- Supports USB(\*1) plug and play to easily read and store data.

## PDU2 Power Distribution Unit

Economic Design for sequential on or off of 2 SUBsidiary units.



## ○ World First Innovation

- PDU2, 1U height, control 2 units 18kW iDRC DC power supply.
- MAX power rate at 36KW
- CE approved

## ○ Electrical

- 3Ø180~460VAC, 47~63Hz universal Input
- Sequential power ON/OFF.
- Easy to replace output terminal.

## ○ Safety

- SEMATECH std. EMO button, physically off all managed DC power supply at once.
- Distinct AC Output On/Off button to On/Off DC power supply in sequence..

\*1. The format of USB flash drive should be FAT16(2GB) or FAT32(32GB) USB2.0

## Functions and Displays of PDU10/PDU6

PDU10/PDU6 provide various readings in different pages.

### Turn MEAS knob to switch between pages

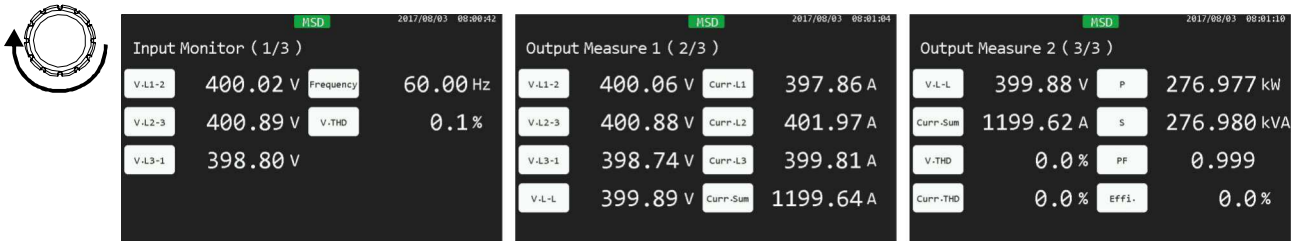

### Dedicated TIME knob for all time related parameter adjustments

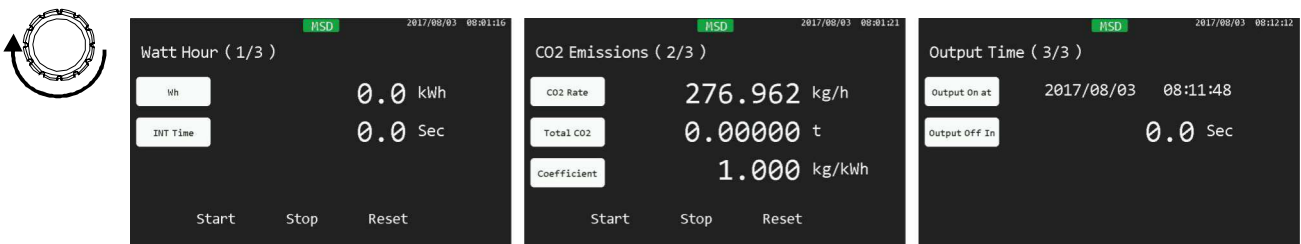

## Models Function List

	PDU10	PDU6	PDU2
Channels	10	6	2
Parallel Units	10	10	
Remote Monitoring	V	V	
Sequence On/Off	V	V	
Number of On/Off Setting	V	V	
LXI1.5	V	V	
Web Server	V	V	
NTP Sync.	V	V	
4 Input Readings	V	V	
9 Output Readings	V	V	
5 Protections	V	V	
Off Time Setting	V	V	
Interlock	3	3	1
No. of Ext. EMO Input	2	2	
Tower Light Output	V	V	
Buzzer Output	V	V	
Thermo Switch Input	V	V	
EMO Button	V	V	V
5" 800x480 Touchscreen	V	V	
Stanless Steel Case	V	V	V

### 4 Input Readings

1. Voltage(L1,L2,L3)
2. Frequency
3. Voltage THD
4. Phase Loss

### 9 Output Readings

1. Current(L1,L2,L3)
2. Effective Power
3. Reactive Power
4. Power Factor
5. Voltage THD
6. Current THD
7. KWh
8. CO2 Emmission
9. Efficiency

### 5 Protections

1. Line Voltage High
2. Line Voltage Low
3. Output Current High
4. Output Over Loading
5. Magent Contact Fail

## Web Server Function

The PDU10/PDU6 provides a web GUI allowing users to control the DC power system via ethernet.

**Instrument Welcome Page**

Device Model	PDU10
Manufacturer	IDRC
Serial Number	000000
Description	PDU10_000000
LXI Extended Features	LXI HSLIP
LXI Version	1.4 LXI Device Specification 2011
Hostname	PDU10_000000.local
MAC Address	70:46:42:8C:65:F1
TCP/IP Address	192.168.42.203
Firmware Revision	0.36.00
Instrument Address String	TCPIP0::192.168.42.203::5025::SOCKET TCPIP0::192.168.42.203::HSLIP0::INSTR
Device Indicator	Inactive <input type="button" value="Toggle"/>

<Web server information>

Output	OFF	
Integrate	OFF	
Freq:	60.00	Hz
U <sub>12</sub> :	400.19	V
U <sub>23</sub> :	401.01	V
U <sub>31</sub> :	398.83	V
THD <sub>U</sub> :	0.1	%
I <sub>1</sub> :	397.95	A
I <sub>2</sub> :	402.18	A
I <sub>3</sub> :	399.80	A
THD <sub>I</sub> :	0.1	%
P:	277.134	kW
S:	277.137	kVA
PF:	1.000	
Effi:	0.0	%
WH:	0.0	kWh
Int. time:	0	Sec
CO <sub>2</sub> Rate:	277.133	kg/h
Total CO <sub>2</sub> :	0.00000	t
Off in:		

<Parameters>

## PDU Application Example

Our innovative, patented Power Distribution Unit design consolidates control and management of two hundred thousand VA AC mains in a 4U chassis. This significantly simplifies the control and wiring for a 180 kW DC Power System.

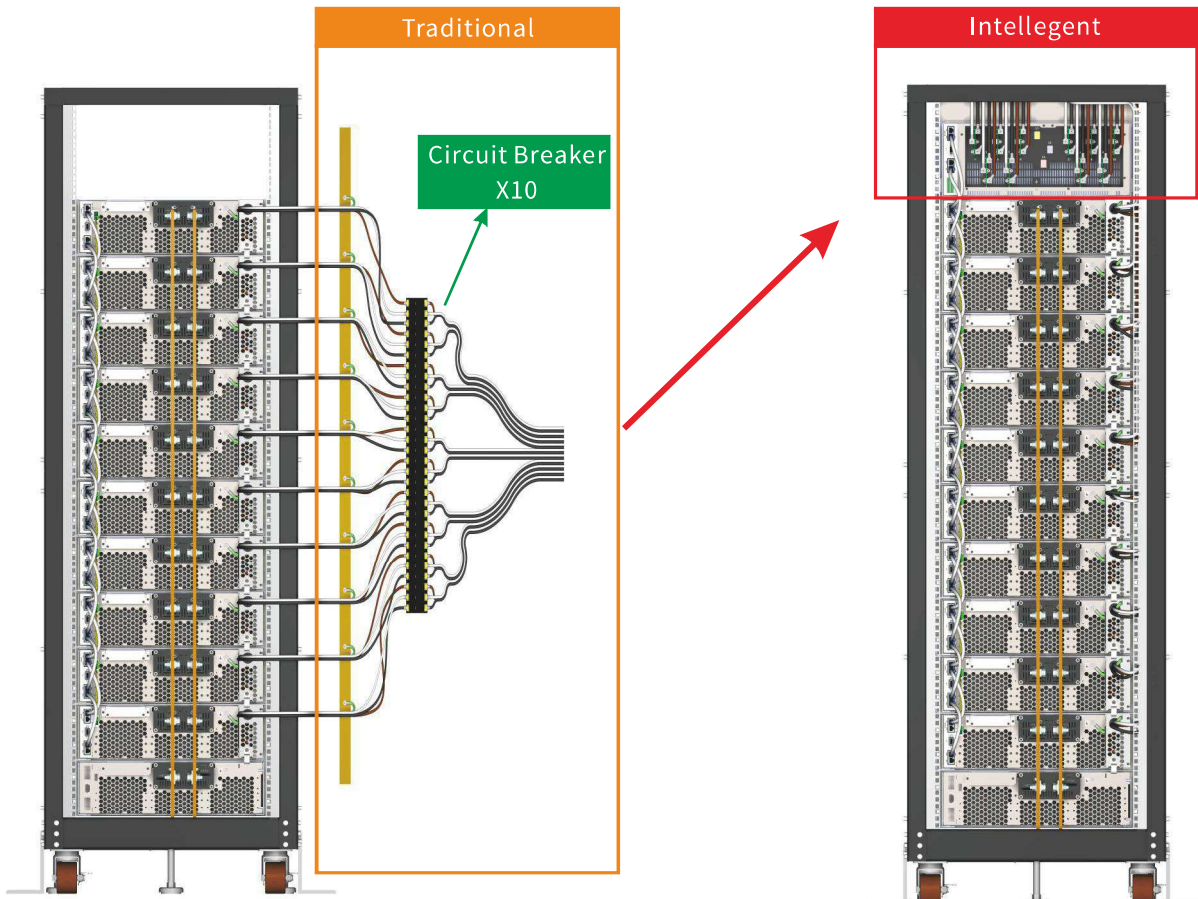

Model number	PDU10		PDU6	PDU2
Numbers of unit power ON	1~10		1~6	1~2
<b>Input &amp; Output Specification</b>				
Voltage range	180~460VAC , Optional 480VAC type:432~528VAC			
Nominal voltage	15kW : 200 / 208 / 220 / 380 / 400 / 415VAC 18kW : 380 / 400 / 415VAC			
Phase/Wires	3-phase / 3 wires			
Frequency range	45Hz ~ 65Hz			
5kW / 10kW / 15kW type (at 180V 3-phase)	Max. Current	600A / Phase	360A / Phase	120A / Phase
	Max. Power	180kVA	108kVA	36kVA
6kW / 12kW / 18kW type (at 340V 3-phase)	Max. Current	400A / Phase	240A / Phase	80A / Phase
	Max. Power	216kVA	130kVA	44kVA
<b>Setting Function</b>				
Nominal voltage setting	15kW : Selectable 200 / 208 / 220 / 380 / 400 / 415VAC 18kW : Selectable 380 / 400 / 415VAC			-
Frequency setting	Selectable 50Hz/60Hz			-
Power OFF timer setting	DDD/HH/MM			-
Interlock I/O number	1~3			-
CO <sub>2</sub> emission factor setting	0.000kg/kWh - 9.999 kg/kWh			-
<b>Control Function</b>				
Power ON order	The power ON order is from the last Slave unit to the Master unit.			
Power OFF order	The power OFF order is from the Master unit to the last Slave unit.			
Power ON/OFF control	Manual/Timer/Remote			-
<b>Input measurement</b>				
Voltage (L1, L2, L3)	Range	600V / 300V		-
	Resolution	0.01V		-
	Accuracy	± 0.2%		-
Frequency	Resolution	0.001Hz		-
	Accuracy	± 0.2%		-
<b>Output measurement</b>				
Current (L1, L2, L3)	Range	600A / 300A / 60A	600A / 300A / 60A	-
	Resolution	0.01A		-
	Accuracy	± 0.8%		-
Active Power (P)	Resolution	0.001kW		-
	Accuracy	± 1.5%		-
Apparent Power (S)	Resolution	0.001kVA		-
	Accuracy	± 1.5%		-
Power Factor	Resolution	0.001		-
	Accuracy	± 1%		-
Kilo-Watt-Hour	Resolution	0.1 kWh		-
	Accuracy	± 1.5%		-
CO <sub>2</sub> emission	Real time	0000.000 ~ 9999.999kg		-
	Accumulate	0000.0000t ~ 9999.9999t		-
Efficiency (DC power supply output/input)	Resolution	0.1%		-
	Accuracy	± 1.5%		-
Voltage	Resolution	0.1%		-
Total Harmonic Distortion	Accuracy	± 1%		-
Current	Resolution	0.1		-
Total Harmonic Distortion	Accuracy	± 1%		-
<b>Safety and Protection</b>				
Emergency Stop	EMS button on the front panel			-
OVP	+10% of Nominal input			-
UVP	-10% of Nominal input			-
OCP	+10% of Max. input current			-
OLP	Adjustable from 18kVA to 180kVA   Adjustable from 18kVA to 108kVA			-
Frequency	±3Hz at 50Hz/60Hz			-
Phase loss	Alarm and stop operation when lose any phase.			-
<b>Status Indication on the LCD display</b>				
REMOTE	REMOTE will show on the LCD display when the PDU is connected to PC			-
KEY LOCK	KEY LOCK will show on the LCD display when the keys are locked			-
Error	ERR will show on the LCD display when any error occurs			-
<b>Digital interface - LAN</b>				
Standard	LXI			-
Line ending character	Reception : LF , END ; Transmission : LF+END			-
<b>External Control I/O</b>				
EMS	1. Multiple rack cabinet EMS can be connected in series. 2. Extendable EMS switch.			-
Interlock	Equipped with three interlock connectors (in series).			-

## PDU Series Specifications

Model number	PDU10	PDU6	PDU2	
Control units	1~10	1~6	1~2	
<b>General specification</b>				
Auxiliary Power Supply	Input voltage	180~460VAC ,Optional 480VAC for 15kW model		
	Frequency	45Hz ~ 65Hz		
	Power consumption	≤55W	≤46W	≤35W
	Standby power	≤30W	≤30W	≤10W
Environmental Condition	Operating environment	Indoor use		
	Operating temperature	0°C ~ 50°C		
	Operating humidity	30%rh ~ 80%rh (no condensation), 80% RH at 30°C , . Decrease linearly to 50% RH at 40°C		
	Storage temperature	-20°C ~ 70°C		
	Storage humidity	10%rh ~ 80%rh (no condensation)		
	Altitude	Up to 2000m		
Withstanding voltage	Primary - Chassis	DC2500V		
	Primary - Secondary	DC2500V		
	Secondary - Chassis	DC2500V		
<b>Physical specification</b>				
Display panel	TFT LCD Touchscreen 127mm(5" - 800x480 )		-	
Dimensions (W x H x D)	440 x 176 x 849.6 mm		-	
Weight	40kg	35kg	12kg	
<b>Accessories</b>				
LAN cable	2m		-	
RS485 cable	1pc (AWG24-2m)		-	

\*1. All parameters are measured after 30 minutes warm-up. Ambient temperature at 23±5°C, Humidity Under 80% RH, AC Voltage : 415V±5%, Frequency : 50/60Hz±5%.

## Rear Panel

### PDU10/PDU6

- ① MAIN / SUB Port
- ② Digital I/O
- ③ LAN (LXI) connector
- ④ I/O Port
- ⑤ Line In
- ⑥ Line Out
- ⑦ Ground Terminal

### PDU2

- ⑧ Line In
- ⑨ Ground Terminal
- ⑩ I/O Port
- ⑪ Line Out

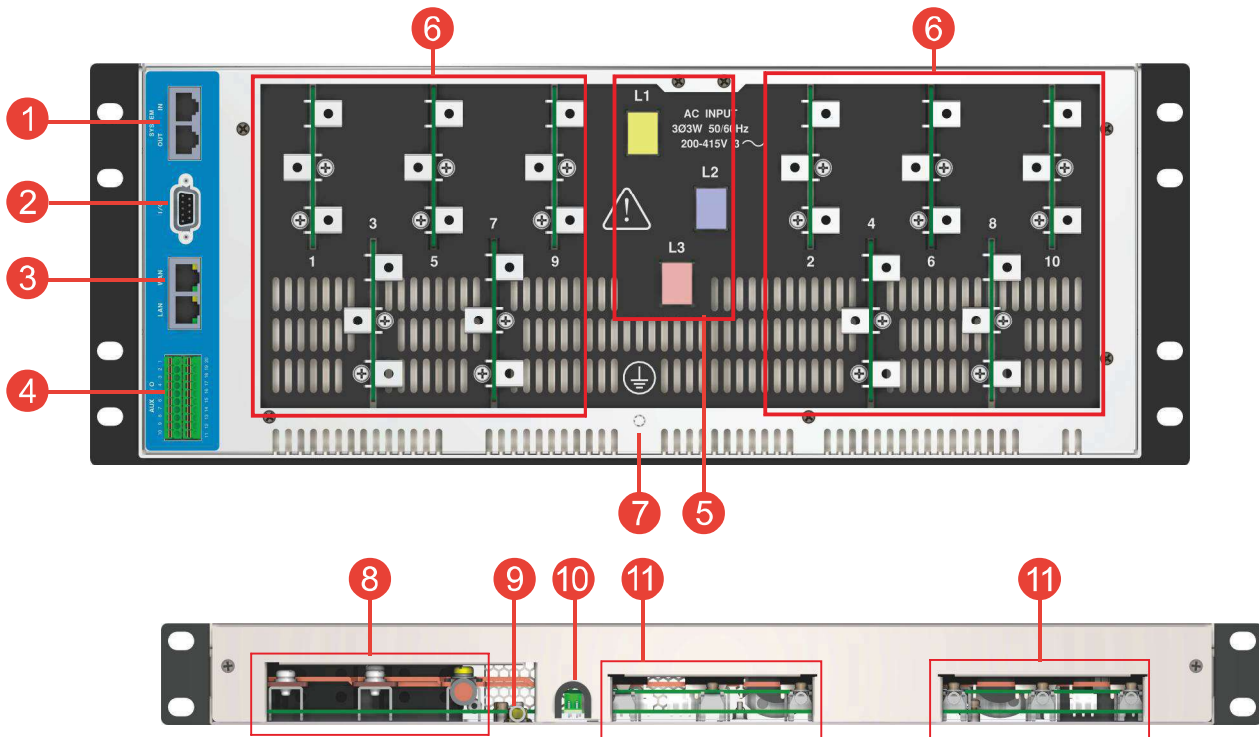

## DC-RACK Series Specifications

- 4 kinds of rack for 150kW / 90kW / 60kW / 30kW (15kW type) or 180kW / 108kW / 72kW / 36kW (18kW type) DSP-Wx wide range DC power supply.
- Professional wiring at factory.
- Standard PDU series handles MAIN / SUB control between racks.
- Accessories include anti-tilt stand, inner power cable/copper bar and installation tool kits.

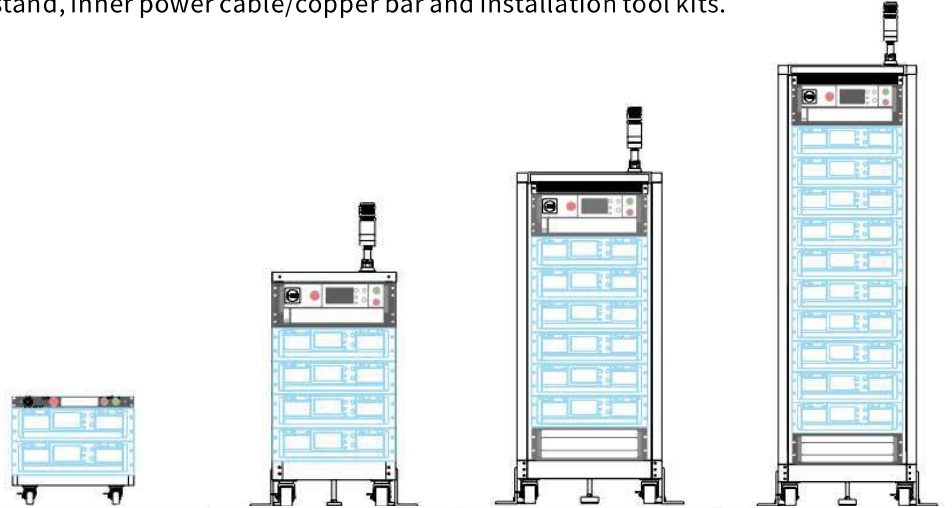

Model name	DC-RACK2	DC-RACK4	DC-RACK6	DC-RACK10
Description	2 units DSP-Wx in parallel	4 units DSP-Wx in parallel	6 units DSP-Wx in parallel	10 units DSP-Wx in parallel
Height	7U	16U	26U	38U
Model no.	PDU2	PDU6	PDU6	PDU10
Application model	DSP-WR, DSP-WE, DSP-WA, DSP-WAe Series Wide Range Programmable DC Power Supply DSP-WS, DSP-WAs Series Solar Array Simulator			
Capacity	2	4	6	10
Power Range	36kW ~5kW	72kW ~ 5kW	108kW ~ 5kW	180kW ~ 5kW
Rack Dimension (WxHxD)mm	482 x 426 x 722	490 x 932 x 996	601 x 1380 x 1000	601 x 1915 x 1000
Rack incl. Stand (WxHxD)mm	482 x 426 x 778	667.1 x 1206 x 1038	783.2 x 1654 x 1035.6	783.2 x 2189 x 1035.6
Rack weight (kgs)	24~25	107~141	201~225	243~294
Rack incl. wiring weight (kgs)	111~115	282~322	463-495	679~745

Paralleling **100** units up to **1800kW**

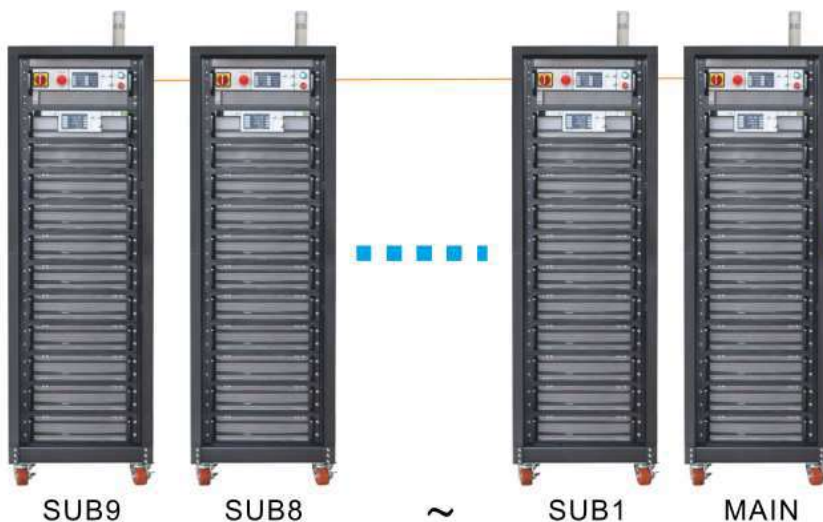

- Unique digital synchronization technique.
- PDU MAIN / SUB control capability  
Manage millions of watts via a single Ethernet cable.



# Glance of DC-RACK

- 1 Tower Light
- 2 AC Mains Switch
- 3 EMO Button
- 4 Subs Sequence On Button
- 5 Subs Sequence Off Button
- 6 DC Output On/Off Key
- 7 DSP-Wx DC Power Supplies
- 8 Rack Mounting Clipper
- 9 Options
  - WR-OPT-FD Freewheeling Diode
  - WR-OPT-CB Capacitor Bank
  - WR-OPT-DC Discharging Device
  - WR-OPT-RP Reverse Protection

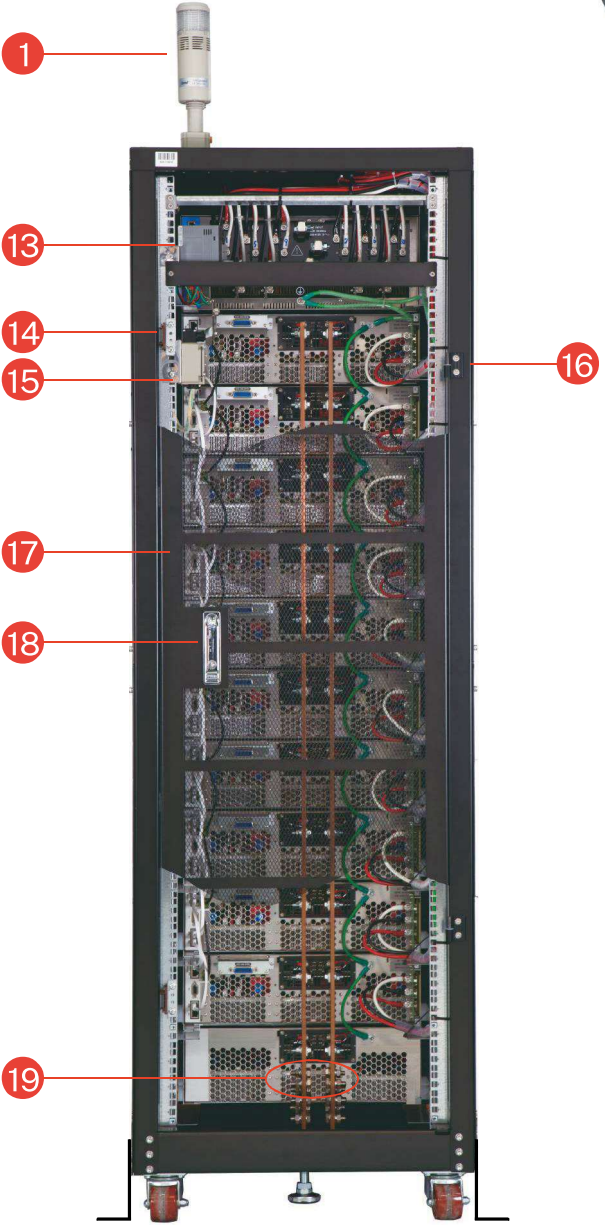
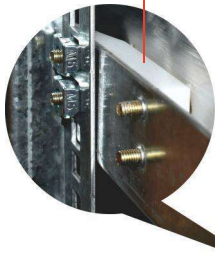
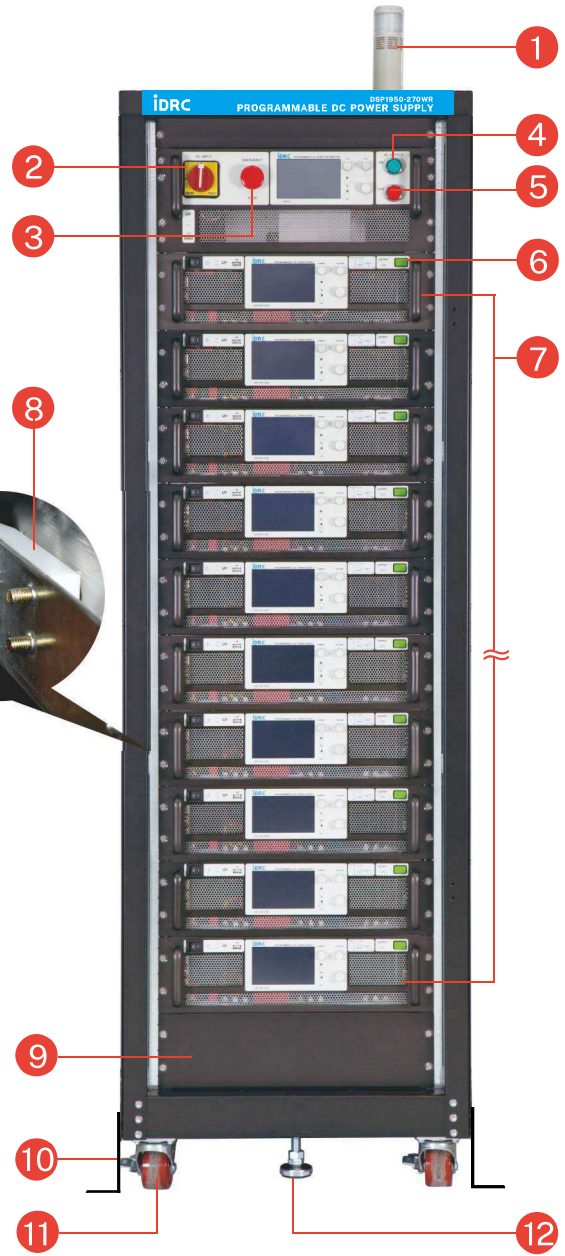

- 10 Anti-tilt Shaft
- 11 Heavy Loading Tire(wheel)
- 12 Leveling Bolt
- 13 4 Ports Hub
- 14 Magnet Lock
- 15 Door Interlock
- 16 Door Bolt
- 17 Rear Door
- 18 Handle
- 19 Output Copper Bar



DC-RACK Dimensions(mm)

DC-RACK10

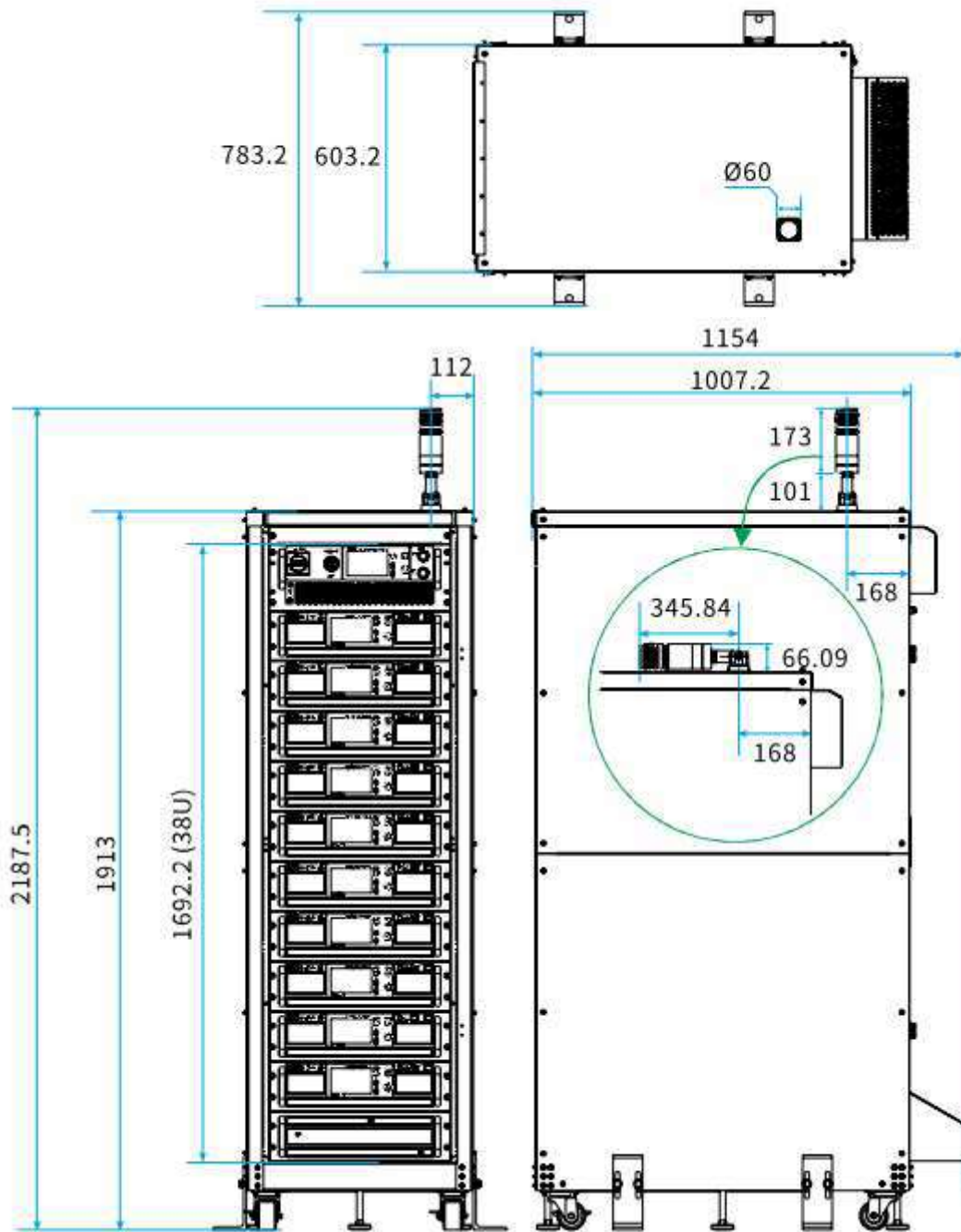

DC-RACK2

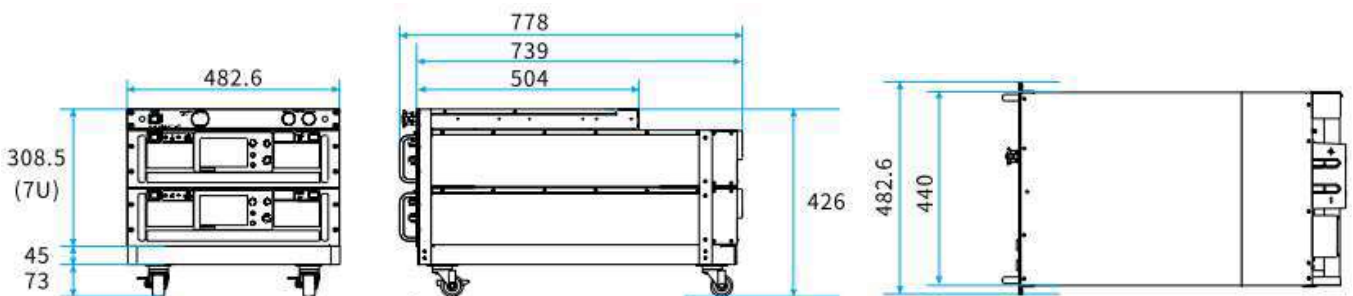

For reference only. May vary slightly on order.

DC-RACK Dimensions(mm)

DC-RACK6

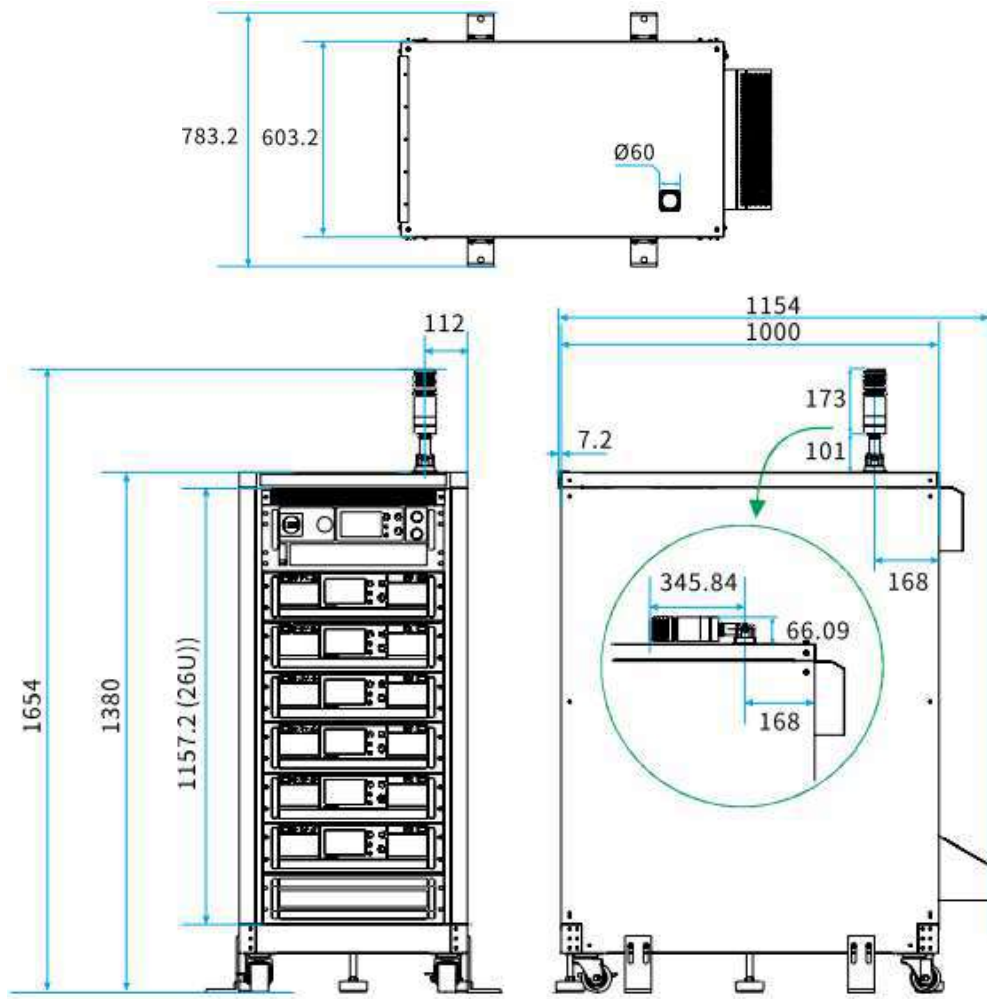

DC-RACK4

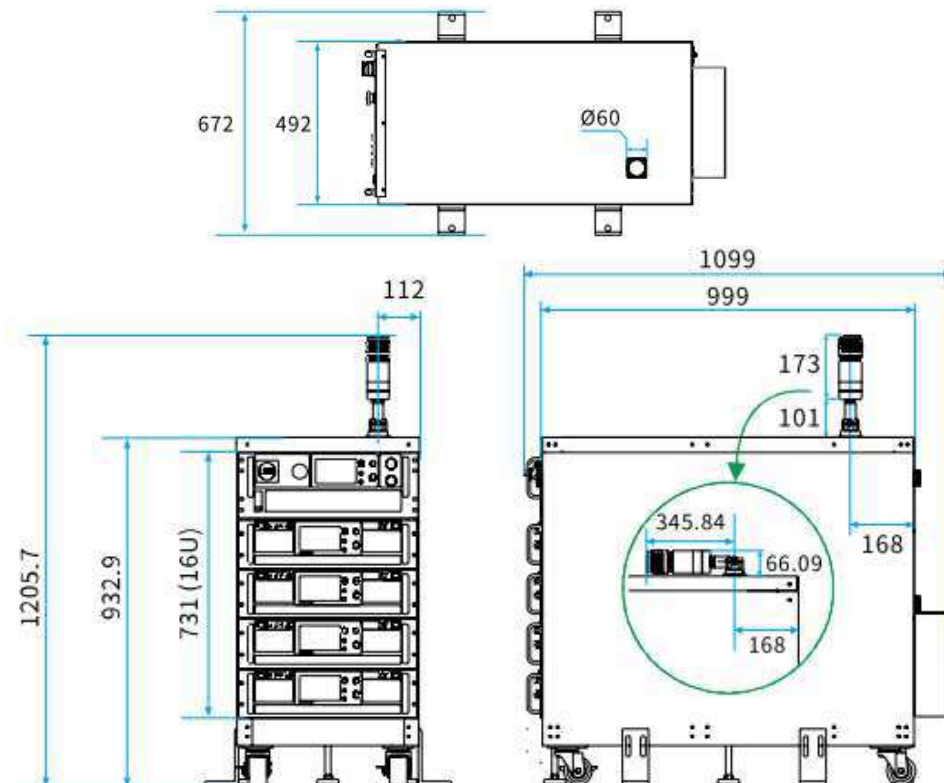

For reference only. May vary slightly on order.

## Quick Reference Charts

Series	DSP-WR	DSP-WS	DSP-WE	DSP-WA	DSP-WAs	DSP-WAe
Symbol	<b>R</b>	<b>S</b>	<b>E</b>	<b>A</b>	<b>As</b>	<b>Ae</b>
Voltage range	80V~1950V	650V~1950V	80V~1950V	80V~1950V	650V~1950V	80V~1950V
Current	540A~23A	69A~23A	540A~23A	540A~23A	69A~23A	540A~23A
LCD size	5"	5"	5"	X	X	X
LCD resolution	800x480	800x480	800x480	X	X	X
Output ON priority	CV,CC,CP	CV,CC,CP,I/V	CV,CC	CV,CC,CP	CV,CC,CP,I/V	CV,CC

Function	Models
Touch screen	<b>R</b> <b>S</b> <b>E</b>
Front USB	<b>R</b> <b>S</b> <b>E</b>
CV adjust	<b>R</b> <b>S</b> <b>E</b> <b>A</b> <b>As</b> <b>Ae</b>
CC adjust	<b>R</b> <b>S</b> <b>E</b> <b>A</b> <b>As</b> <b>Ae</b>
CP adjust	<b>R</b> <b>S</b> <b>A</b> <b>As</b>
Internal resistance	<b>R</b> <b>S</b> <b>A</b> <b>As</b>

Function	Models
Operating Mode - Simple mode	<b>R</b> <b>S</b> <b>E</b>
Operating Mode - Complete mode	<b>R</b> <b>S</b> <b>E</b>
Operating Mode - Sequence mode	<b>R</b> <b>S</b> <b>E</b>
Operating Mode - Insertion mode	<b>R</b> <b>S</b> <b>E</b>
Operating Mode - SAS curve	<b>S</b> <b>As</b>
Operating Mode - SAS table	<b>S</b> <b>As</b>
Voltage slew rate	<b>R</b> <b>S</b> <b>E</b> <b>A</b> <b>As</b> <b>Ae</b>
Current slew rate	<b>R</b> <b>S</b> <b>E</b> <b>A</b> <b>As</b> <b>Ae</b>
Power slew rate	<b>R</b> <b>S</b> <b>E</b> <b>A</b> <b>As</b> <b>Ae</b>

## Options

Function	Description
WR-OPT-FUA	Firmware update adapter
WR-OPT-422U	RS-422+RS485+USB interface
WR-OPT-ANA	Isolated Analog Interface
WR-OPT-488	IEEE-488 (GPIB) interface
WR-OPT-ICE	AC Input Cover Assembly +Nylon Cable Gland
WR-OPT-ICN	AC Input board Assembly
WR-OPT-OPC	Output protection cover
WR-OPT-CAB	Parallel cable kit
WR-OPT-2EC	2m Ethernet Cable
WR-OPT-AC480	AC 3Ø4W 480V input (input range AC 432V ~ 528V)
WR-OPT-DC550	DC 500V input (input range DC400V ~ DC600V)
WR-OPT-TOOL	Install tool kit
WR-OPT-PBB	Parallel bus bar(80V 10kW/15kW model only)
WR-OPT-DC	Discharge Circuit(*1)
WR-OPT-CB	Capacitor Bank(*1)
WR-OPT-FD	Freewheeling diode(*1)
WR-OPT-RP	Reverse Protection(*1)
DC-RACK10	38U Rack assembly (include rack,PDU10,AC mains and DC output wiring)
DC-RACK6	26U Rack assembly (include rack,PDU6,AC mains and DC output wiring)
DC-RACK4	16U Rack assembly (include rack,PDU6,AC mains and DC output wiring)
DC-RACK2	7U Rack assembly (include rack,PDU2,AC mains and DC output wiring)

\*1. Various voltage/current/power/time specifications, please contact iDRC before order.

## Options

- ◆ **WR-OPT-ICE**  
AC input cover assembly  
+nylon cable gland



- ◆ **WR-OPT-ICN**  
AC Input board  
Assembly



- ◆ **WR-OPT-DC**  
Discharge Circuit

- ◆ **WR-OPT-CB**  
Capacitor Bank

- ◆ **WR-OPT-FD**  
Freewheeling Diode

- ◆ **WR-OPT-RP**  
Reverse Protection

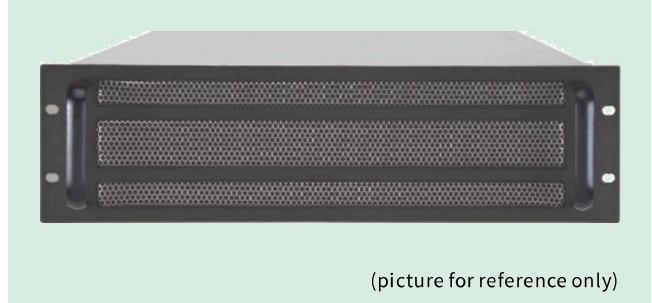

- ◆ **WR-OPT-OPC**  
ABS plastic output  
protection cover



- ◆ **WR-OPT-FUA**  
Firmware update  
adapter



- ◆ **WR-OPT-TOOL**  
Installation tool kit



- ◆ **WR-OPT-PBB**  
Parallel bus bar  
(80V model only)



\* The color and style of WR-OPT-FUA and WR-OPT-TOOLS may vary.

## Ordering Information

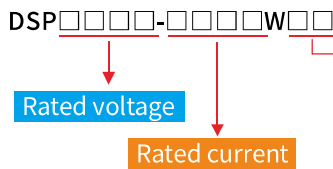

- R : DSP-WR 5" touchscreen, full function models
- E : DSP-WE 5" touchscreen, economic models
- S : DSP-WS 5" touchscreen, solar array simulators
- A : DSP-WA ATE purposed(CV/CC/CP) or SUB unit for DSP-WR
- Ae : DSP-WAe ATE purposed(CV/CC) or SUB unit for DSP-WE
- As : DSP-WAs ATE purposed(CV/CC/CP) or SUB unit for DSP-WS

PN:8101-0045 Ver 1.5



VP ELECTRONIQUE