



**VP** ELECTRONIQUE

1UH Series



1U Series



2UH Series



2U Series



# High Resolution

# Programmable DC Power Supply

## Environmental Mission / iDRC and the Environment

We are devoting to product Innovation and development, also effort to environmental protection as social responsibility. While enhancement of our products, the influence of our products to the environment throughout their life cycles has been concerned and controlled by our environmental management that we focus on reducing the impact from product design, material use, manufacturing, packaging, transportation, product use, and recycling.

### ● Purpose of Design

Our purpose of designing and producing the products is to allow every customer to have more efficient use of energy and be able to obtain power in an environmentally friendly way. Furthermore, our products are aimed to help our customers understand the energy operation better in order to precisely develop and design remarkable energy applied products.

Our products include DC power supply, AC power source and Power analyzer. They are mainly used in Wind, Solar and other green power energy research and development laboratories, all kinds of electric vehicles, home appliances and IT products R&D and production. We aim to help these environmentally friendly energies to be well accepted and all of our customers are able to design/develop low consumption products that not only meet the standard but also help to reduce gas emission.



### ● Eliminating Toxic Materials/Substances

We are very strict in selecting materials/substances that we do not use any harmful/toxic substances neither in our products nor packaging. All of our products and packaging strictly follow the rules of RoHS Directive, WEEE and other environmental laws/regulations. We do not only forbidden using harmful toxins, but also seek to exclude the possibility of use of harmful materials in our products.

### ● High Efficiency

From the perspective of high efficiency, we use low consumption equipments (i.e., information equipments that meet EAP energy efficiency requirements) for design. Meanwhile, we also select low-power components and apply the latest technology to reduce energy conversion losses. Applying Active Power Factor Correct (APFC) into the products makes the PF of the products higher than 0.95, which helps to improve the electricity quality of each product and reduce 20%~50% or more of energy waste.

We use the power regeneration load when testing/manufacturing which can reduce the energy consumption.

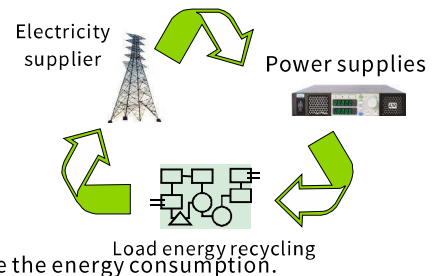

### ● Smaller Volume、 Less energy waste

Designing small, compact, efficient product is another main goal of iDRC. This way can help to use less materials of packaging, and also enhance the efficiency of transportation. Hence, CO2 emission produced during transportation (from vehicles and ships) can be efficiently reduced.



### ● Life

Using high quality components and applying completed protection function into our product makes the life cycle of our products is either much longer or the failure rate is lower than the competitors. It is efficient to reduce CO2 emission and waste produced during transportation, maintenance, and obsolescence.



### ● Recycle

The recyclability of our products is higher than 85%. It means the impact of non-recyclable components to the environments will be reduced.

# Innovation

After decades of research and development, iDRC has obtained 290 patents (through October 2022), more than 57 invention patents.



# Safety certification

## Electromagnetic Compatibility

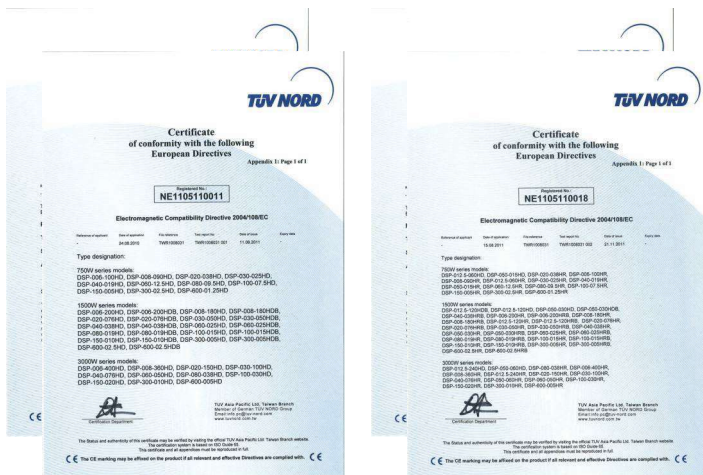

## Vibration Test

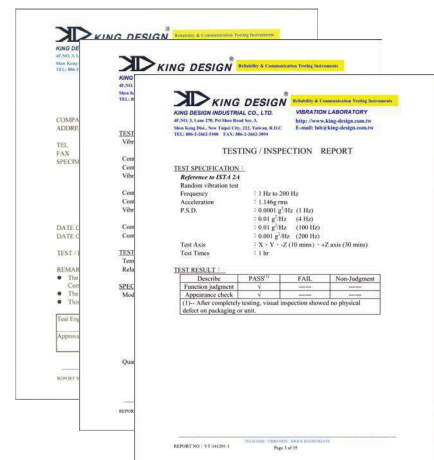

## Low Voltage Directive



## Filled Transport Packages

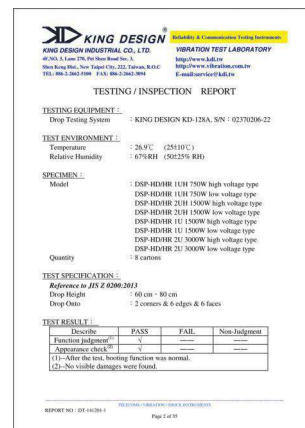

## Guarantee

iDRC commit to deliver the highest quality products. A great deal of high-precision instruments have been employed during development and production.

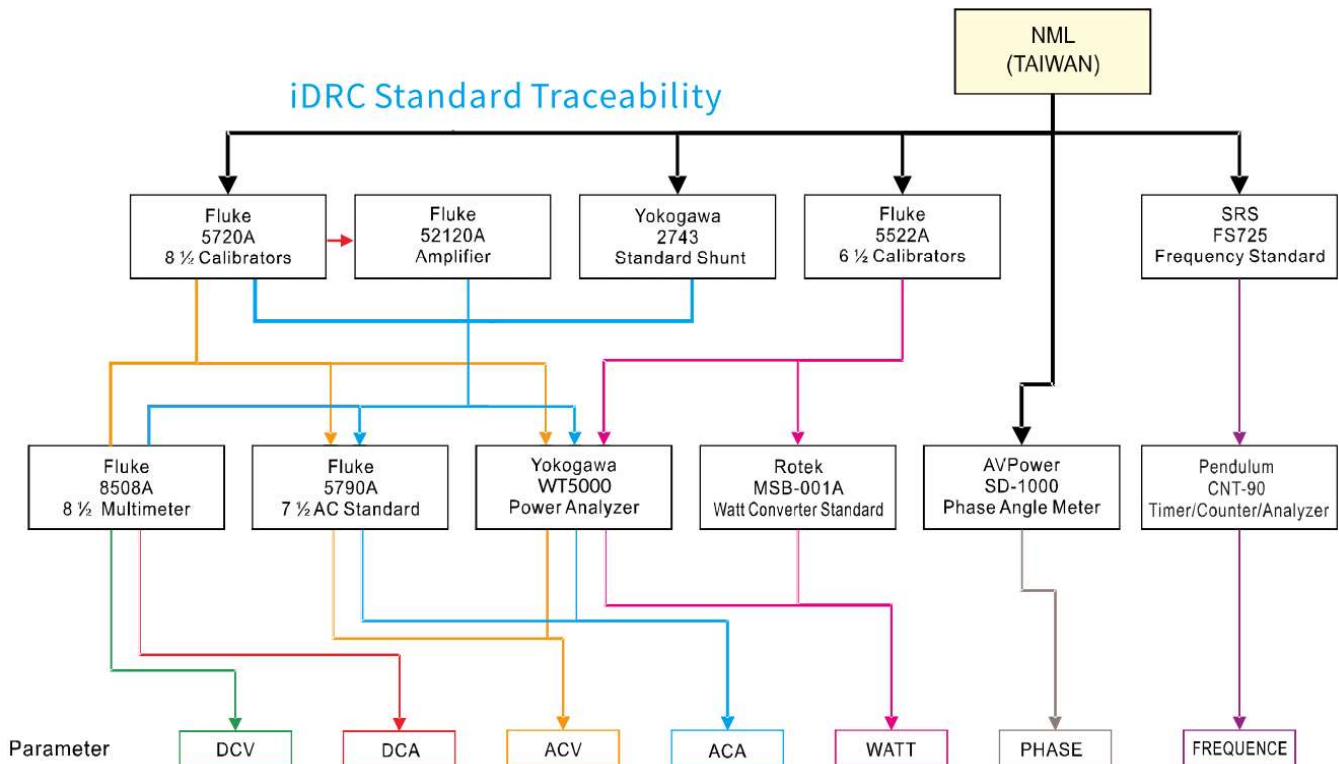

## Calibration Equipment

**FLUKE** : 5720A , 5700A , 5522A , 5520A , 5500A , 52120A , 5790A , 8508A 、 HP 3458A 、 Guildline 7620 、  
**SRS** : FS725 , SR620 、 **Pendulum** CNT-90 、 **Yokogawa** : WT5000 , WT3000 , 2743 [2A , 5A , 10A , 20A , 50A ,  
 100A] ) 、 **Danisense** Fluxgate DCCT : 600A , 700A , 2000A 、 **LEM** Ultrastab DCCT : 60A , 150A , 600A , 700A ,  
 1000A , 5000A 、 **ROTEK** MSB-001A 、 **AVPower** SD-1000 etc.

## Development Instrumentation

**Keysight/Agilent/HP** : PA2201A , PA2203A , MSOX6004A , 53230A , 33522B , B2962A , 34470A , 34420A ,  
 34461A , 34401A , L4534A , L4532A , U1620A , 3245A , 4284A+42841A 、 **ADCMT** 7461A 、  
**AudioPrecision** APx525 、 **Fluke** : 8842A , 8846A , 190-104 、 **Tektronix** : 370A , TPS2024 , TPS2014 、  
**Keithley** : 2000 , 2015 、 **Hioki** : 3390 , 3196 , 3197 , PW3198 、 **IWATSU** : CS3100 , CS3200 , CS3300 ,  
 DG-8000 , VOAC7602 、 **Kikusui** : TOS-9201 , TOS-6200 , TOS-7200 , TOS-3200 , TOS-5101 、  
**Lecroy** : HDO8108A-MS , MDA810A , HDO6104A-MS , HDO4054A-MS , WR66Zi-HRO , DA1855A , DA1855A-PR2 、  
**NF** : FRA5097 , FRA5087 , WF1948 , WF1974 , WF1946 , CK1620 、 **R&S** AM300 、 **SRS** DS360 、  
**Tabor** WW2074 、 **Yokogawa** : WT5000 , WT3000 , WT1800 , PX8000 , DL750 , SB5710 , SL1000 ,  
 DL7480 etc.

note: The names and logos mentioned in this catalog are the property of the mentioned companies

# DSP-HR series

## Programmable DC Power Supply



### Features

- Up to 60 models: 6V~600V/1A~400A are available for selection.
- Up to 5 units in parallel or 2 units in series, come standard with active current sharing.
- Maximum output current up to 2000A (5 units in parallel)
- 100-240Vac universal input for 750W and 1500W models , 220Vac for 3000W models.
- Unique bench top 2UH 1500W and flexible rack-mountable arrangement 1UH-750W, 1U-1500W or 2U-3000W.

### Electrical

- Unique interleave technologe delivers low ripple & noise and rapid transient response.
- Active power factor correction circuit presents 0.99PF.
- Fast and automatic switch-over between constant voltage and constant current mode.
- Embedded 3 RISC Micro-Controllers.
- 16 bit DAC for setting and 24 bit ADC for measuring.
- Built-in remote sensing with max. 5V compensation.

### Operational

- 5 digit current and voltage meter
- 16 sets recallable memory accessible via front panel or analog programming interface.
- Programmable ramp up/down times.
- Last setting retainable upon next power on.
- KEY LOCK function.
- Provided Graphical connection control software

### Safety

- OVP, OCP and OTP protection.
- No-gap stacking, front-in and rear-out ventilation.
- Speed-Controlled Fan
- CE approved
- ISTA 2A Vibration Test approved
- JIS Z 0200 Filled Transport Packages Test approved

### Interface

- LXI 1.4 approved
- Standard LXI and isolated RS-485 interfaces, optional GPIB or isolated analog interface.
- Standard analog programming and monitoring port.
- Come standard with IVI-C driver, support SCPI commands.

### DSP-HR 5 Digits Panel



## Front Panel

1UH Series



1U Series



2UH Series



2U Series



## Front Panel and Rear Panel Description

### Front Panel

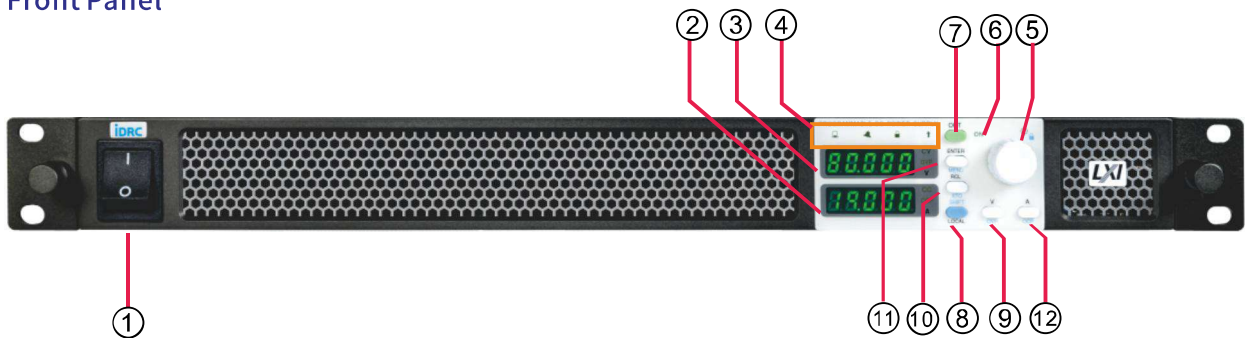

### Rear Panel

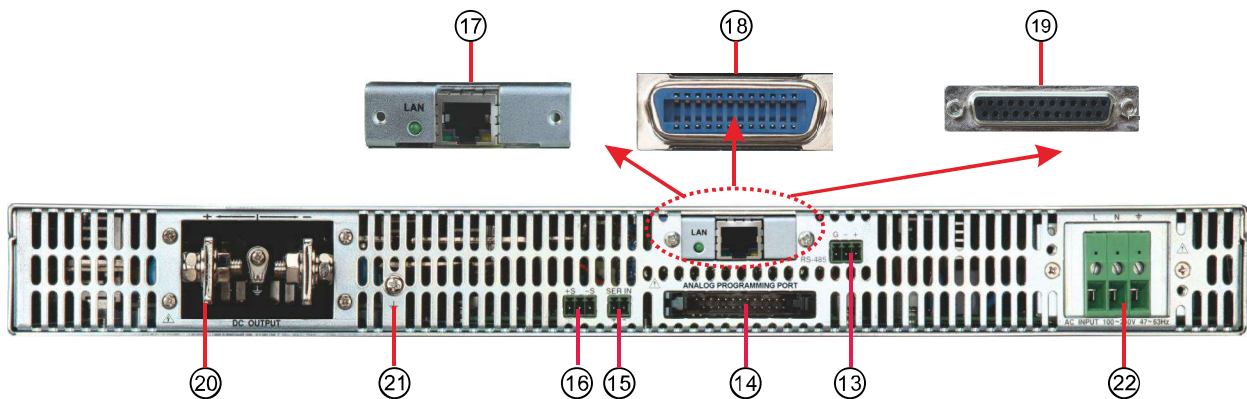

### Front Panel Function Description

- |                                   |                                   |
|-----------------------------------|-----------------------------------|
| 1. Power switch                   | 9.V set & OVP bifunctional key    |
| 2. Current display                | 10.RCL & STO bifunctional key     |
| 3. Voltage display                | 11. ENTER & MENU bifunctional key |
| 4. Operation status indicators    | 12.A set & OCP bifunctional key   |
| 5. Encoder                        |                                   |
| 6. Output ON/OFF indicator        |                                   |
| 7. Output ON/OFF key              |                                   |
| 8. SHIFT & LOCAL bifunctional key |                                   |

Note : Different output terminals depend on different capacities.

### Rear Panel Function Description

- |  |
|--|
| 13.RS-485 interface                      |
| 14.Analog programming interface          |
| 15.Series voltage detection terminal     |
| 16.Remote sense terminal                 |
| 17.LAN (LXI) interface                   |
| 18.IEEE 488 (GPIB) interface (Optional)  |
| 19.Isolation analog interface (Optional) |
| 20.Output terminals (Note)               |
| 21.Grounding terminal                    |
| 22.AC input                              |

**Rear Panel Description**

1UH Series  
6V~100V

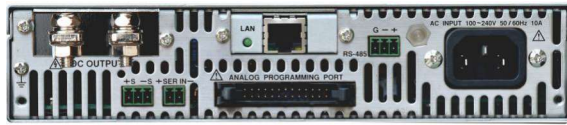

1UH Series  
150V ~ 600V

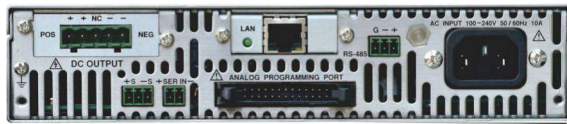

2UH Series  
6V~100V

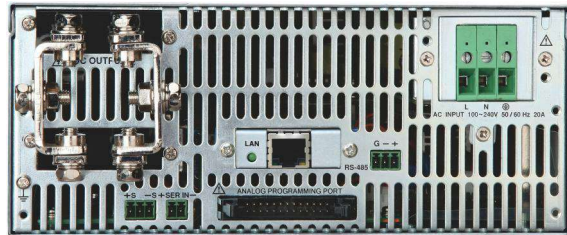

2UH Series  
150V ~ 600V

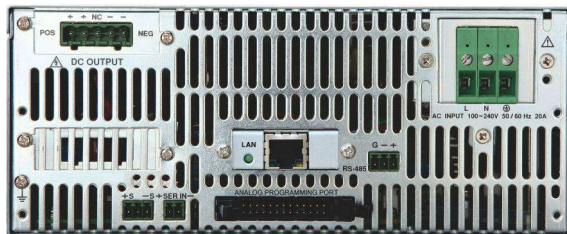

1U Series  
6V~100V

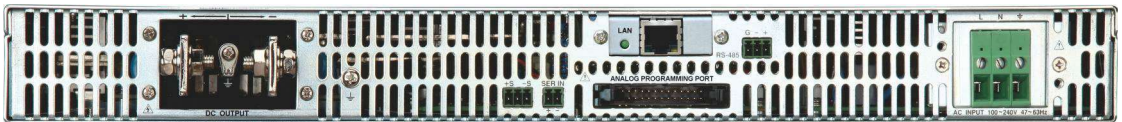

1U Series  
150V ~ 600V



2U Series  
6V~100V

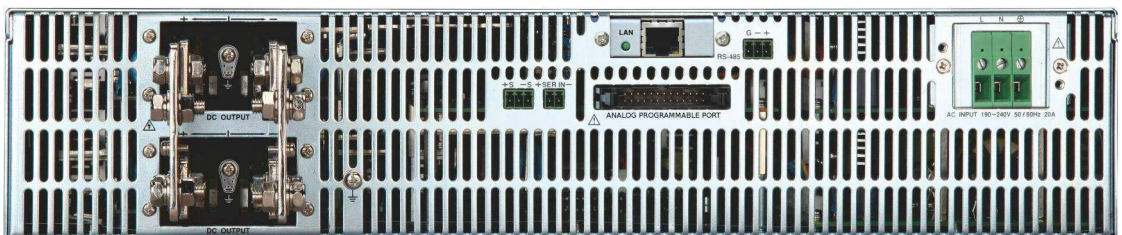

2U Series  
150V ~ 600V

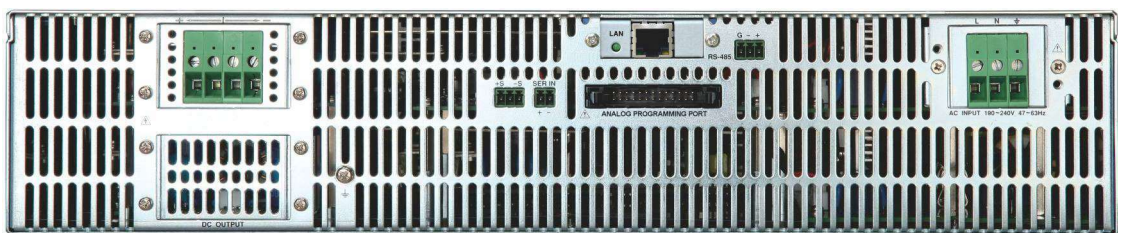

## Functions

### In Series

To enhance the output voltage of the DSP-HR, you can connect units in series with the same model.

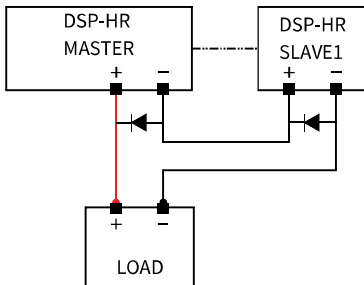

Note: The combined voltage should be lower than 600VDC when connect 2 units in series.

### In Parallel

Up to 5 units in parallel to supply ultra power capacity, surplus slave units can be switched off to save energy.

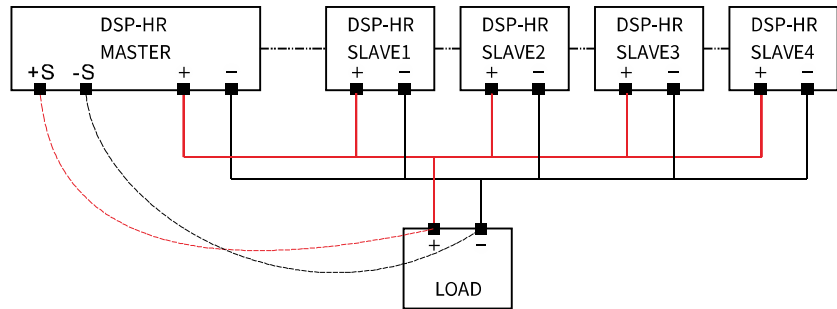

### Remote Sensing

Compensate voltage drop across output leads. Max. compensation voltage up to 5V.

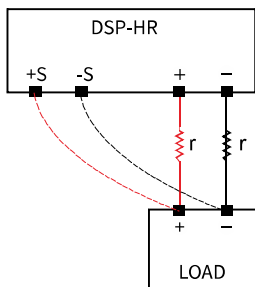

### Analog Control V/A

Through the accurate converter, external analog input 0~10V corresponds to 1~rated of output voltage or current.

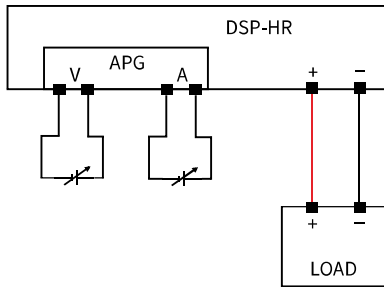

### Analog Monitor V/A

Through the accurate converter, The 0~10V output voltage on APG connectors corresponds to actual output voltage/current.

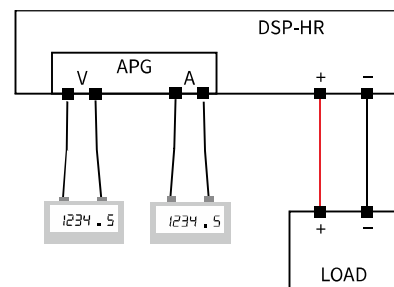

### ON/OFF Control

Various remote control interfaces possible:  
Analog control, Interface programming & Panel control

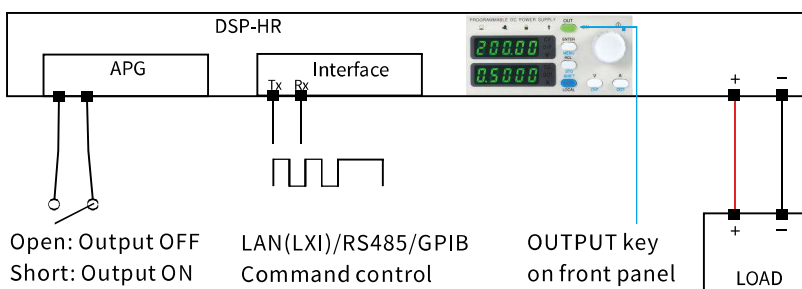

### LXI/RS485/GPIB connection

- LAN(LXI) interface connect unlimited number of units
- RS485 interface connect up to 32 units
- GPIB interface connect up to 14 units

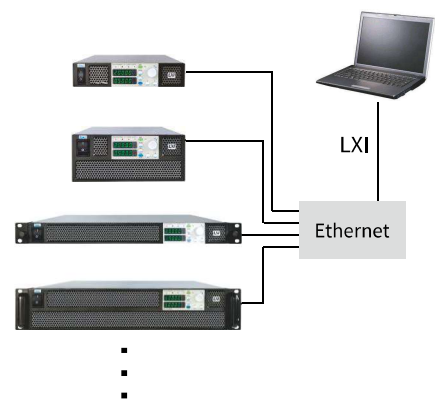



## Specification

### 1UH 750W series

Output		Model	Ripple		Line Regulation		Load Regulation		Response Time(sec)			Remote Sense (V)
CV	CC		CV	CC	CV	CC	CV	CC	Full Load	Full Load	No Load	
V	A		mV	mA	0.05%	0.1%	0.05%	0.1%	UP	Down	Down	
			rms	rms	+mV	+mA	+mV	+mA				
0-6	0-100	DSP-006-100HR	10	180	2.8	11	2.8	23	0.08	0.05	0.6	1
0-8	0-90	DSP-008-090HR	10	180	2.8	11	2.8	23	0.08	0.05	0.6	1
0-12.5	0-60	DSP-012.5-060HR	10	120	4	8.5	4	18	0.08	0.05	0.8	1
0-20	0-38	DSP-020-038HR	10	76	4	5.8	4	12.6	0.08	0.05	0.8	1
0-30	0-25	DSP-030-025HR	10	63	5	4.5	5	10	0.08	0.08	0.9	1.5
0-40	0-19	DSP-040-019HR	10	48	6	3.9	6	8.8	0.08	0.08	1	2
0-50	0-15	DSP-050-015HR	10	43	8	3.6	8	8.2	0.08	0.08	1.1	2
0-60	0-12.5	DSP-060-12.5HR	10	38	8	3.25	8	7.5	0.08	0.08	1.1	3
0-80	0-9.5	DSP-080-09.5HR	10	29	10	2.95	10	6.9	0.15	0.15	1.2	4
0-100	0-7.5	DSP-100-07.5HR	10	23	12	2.75	12	6.5	0.15	0.15	1.5	5
0-150	0-5	DSP-150-005HR	16	18	17	2.5	17	6	0.15	0.15	2	5
0-300	0-2.5	DSP-300-02.5HR	25	13	32	2.25	32	5.5	0.15	0.15	3	5
0-350	0-2.1	DSP-350-02.1HR	17	18	18	2.5	18	6	0.15	0.15	3	5
0-450	0-1.7	DSP-450-01.7HR	34	13	35	2.3	35	5.5	0.21	0.24	3.5	5
0-600	0-1.25	DSP-600-01.25HR	75	8	62	2.13	62	5.26	0.25	0.3	4	5

### 1U 1500W series

Output		Model	Ripple		Line Regulation		Load Regulation		Response Time(sec)			Remote Sense (V)
CV	CC		CV	CC	CV	CC	CV	CC	Full Load	Full Load	No Load	
V	A		mV	mA	0.05%	0.1%	0.05%	0.1%	UP	Down	Down	
			rms	rms	+mV	+mA	+mV	+mA				
0-6	0-200	DSP-006-200HR	15	360	2.8	18.5	2.8	38	0.08	0.05	0.6	1
0-8	0-180	DSP-008-180HR	15	360	2.8	18.5	2.8	38	0.08	0.05	0.6	1
0-12.5	0-120	DSP-012.5-120HR	15	248	3.4	14.5	4	28	0.08	0.05	0.8	1
0-20	0-76	DSP-020-076HR	15	152	4	9.6	4	20.2	0.08	0.05	0.8	1
0-30	0-50	DSP-030-050HR	15	125	5	7	5	15	0.08	0.08	0.9	1.5
0-40	0-38	DSP-040-038HR	15	95	6	5.8	6	12.6	0.08	0.08	1	2
0-50	0-30	DSP-050-030HR	15	85	7	5.2	7	11.4	0.08	0.05	1.1	2
0-60	0-25	DSP-060-025HR	15	75	8	4.5	8	10	0.08	0.08	1.1	3
0-80	0-19	DSP-080-019HR	15	57	10	3.9	10	8.8	0.15	0.15	1.2	4
0-100	0-15	DSP-100-015HR	15	45	12	3.5	12	8	0.15	0.15	2	5
0-150	0-10	DSP-150-010HR	24	45	12	3.5	12	8	0.15	0.15	1.5	5
0-300	0-5	DSP-300-005HR	38	25	32	2.5	32	6	0.15	0.15	3	5
0-350	0-4.2	DSP-350-04.2HR	38	25	32	2.5	32	6	0.15	0.15	3	5
0-450	0-3.4	DSP-450-03.4HR	68	18	35	2.5	32	5.8	0.21	0.24	3	5
0-600	0-2.5	DSP-600-02.5HR	113	15	62	2.26	62	5.5	0.25	0.3	4	5

### 2UH 1500W series

Output		Model	Ripple		Line Regulation		Load Regulation		Response Time(sec)			Remote Sense (V)
CV	CC		CV	CC	CV	CC	CV	CC	Full Load	Full Load	No Load	
V	A		mV	mA	0.05%	0.1%	0.05%	0.1%	UP	Down	Down	
			rms	rms	+mV	+mA	+mV	+mA				
0-6	0-200	DSP-006-200HRB	15	360	2.8	18.5	2.8	38	0.08	0.05	0.6	1
0-8	0-180	DSP-008-180HRB	15	360	2.8	18.5	2.8	38	0.08	0.05	0.6	1
0-12.5	0-120	DSP-012.5-120HRB	15	248	3.4	14.5	4	28	0.08	0.05	0.8	1
0-20	0-76	DSP-020-076HRB	15	152	4	9.6	4	20.2	0.08	0.05	0.8	1
0-30	0-50	DSP-030-050HRB	15	125	5	7	5	15	0.08	0.08	0.9	1.5
0-40	0-38	DSP-040-038HRB	15	95	6	5.8	6	12.6	0.08	0.08	1	2
0-50	0-30	DSP-050-030HRB	15	85	7	5.2	7	11.4	0.08	0.08	1.1	2
0-60	0-25	DSP-060-025HRB	15	75	8	4.5	8	10	0.08	0.08	1.1	3
0-80	0-19	DSP-080-019HRB	15	57	10	3.9	10	8.8	0.15	0.15	1.2	4
0-100	0-15	DSP-100-015HRB	15	45	12	3.5	12	8	0.15	0.15	1.5	5
0-150	0-10	DSP-150-010HRB	24	45	12	3.5	12	8	0.15	0.15	2	5
0-300	0-5	DSP-300-005HRB	38	25	32	2.5	32	6	0.15	0.15	3	5
0-350	0-4.2	DSP-350-04.2HRB	38	25	32	2.5	32	6	0.15	0.15	3	5
0-450	0-3.4	DSP-450-03.4HRB	68	18	35	2.5	32	5.8	0.21	0.24	3.5	5
0-600	0-2.5	DSP-600-02.5HRB	113	15	62	2.26	62	5.5	0.25	0.3	4	5

## Specification

### 2U 3000W series

Output		Model	Ripple		Line Regulation		Load Regulation		Response Time(sec)			Remote Sense (V)
CV	CC		CV	CC	CV	CC	CV	CC	Full Load UP	Full Load Down	No Load Down	
V	A		mV rms	mA rms	0.05% +mV	0.1% +mA	0.05% +mV	0.1% +mA				
0-6	0-400	DSP-006-400HR	23	1000	2.8	42	6.2	85	0.08	0.02	0.5	1
0-8	0-360	DSP-008-360HR	23	1000	2.8	42	6.2	85	0.08	0.02	0.5	1
0-12.5	0-240	DSP-012.5-240HR	23	800	3.2	29	7.1	60	0.08	0.1	0.8	1
0-20	0-150	DSP-020-150HR	23	600	4	18.5	8	38	0.08	0.1	0.8	1
0-30	0-100	DSP-030-100HR	23	310	5	13	9.5	27	0.08	0.16	0.9	1.5
0-40	0-76	DSP-040-076HR	23	250	6	10.5	11	22	0.08	0.16	1	2
0-50	0-60	DSP-050-060HR	23	200	7	9	13	19	0.08	0.16	1.1	2
0-60	0-50	DSP-060-050HR	23	150	8	7.5	14	16	0.08	0.16	1.1	3
0-80	0-38	DSP-080-038HR	23	110	10	6.2	17	13.4	0.15	0.3	1.2	4
0-100	0-30	DSP-100-030HR	23	90	12	5.3	20	11.6	0.15	0.3	1.5	5
0-150	0-20	DSP-150-020HR	36	90	17	4.2	27.5	9.4	0.15	0.3	2	5
0-300	0-10	DSP-300-010HR	57	50	32	3.1	50	7.2	0.15	0.3	3.5	5
0-350	0-8.4	DSP-350-08.4HR	57	50	32	3.1	50	7.2	0.15	0.3	3.5	5
0-450	0-6.8	DSP-450-06.8HR	134	42	43	2.8	84	6.7	0.25	0.5	3.5	5
0-600	0-5	DSP-600-005HR	170	30	62	2.55	95	6.1	0.25	0.5	4	5

### Model reference chart

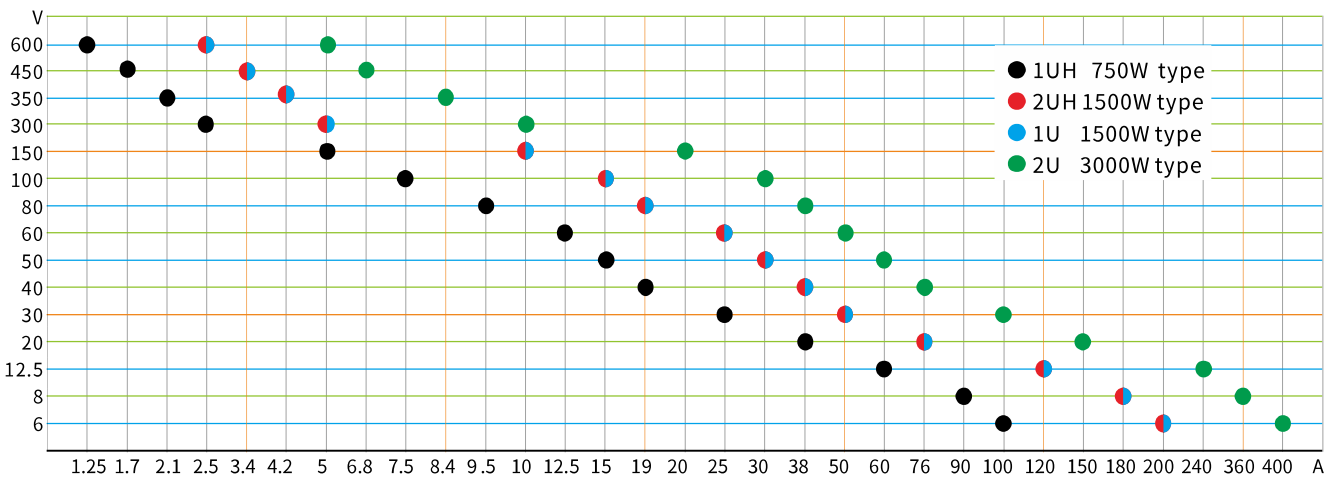

### Model Number Definition

- DSP - 060 - 025 HR B (1)DSP: Series number. iDRC Programmable DC Power Supply.  
 (1) (2) (3) (4) (5) (2)060 : Output voltage , 060 stand for 60V.  
 (3)025 : Output current , 025 stand for 25A  
 (4)HR : High resolution model.  
 (5)B : Bench series (2UH)

## General Specifications

Panel setting resolution	DSP-HR :5 digits
Panel display resolution	DSP-HR :5 digits
Panel setting accuracy	Voltage : $\pm(0.1\% \pm 3 \text{ Count})$ at rated voltage Current : $\pm(0.5\% \pm 3 \text{ Count})$ at rated current
Panel display accuracy	Voltage : $\pm(0.1\% \pm 3 \text{ Count})$ at rated voltage Current : $\pm(0.5\% \pm 3 \text{ Count})$ at rated current
Command setting resolution	$\pm 0.002\%$ of full scale
Command reading resolution	$\pm 0.002\%$ of full scale
Command & DA setting accuracy	Voltage $\pm(0.1\% \pm 3 \text{ Count})$ at rated voltage Current $\pm(0.5\% \pm 3 \text{ Count})$ at rated current
Command & AD Measurement accuracy	Voltage : $\pm(0.2\% \pm 2 \text{ Count})$ at rated voltage Current : $\pm(0.5\% \pm 3 \text{ Count})$ at rated current
Analog setting accuracy(V)	Constant Voltage mode : Voltage 5%(at rated voltage) ; Current 5%(at rated current) Optional Isolated : Voltage 0.5%(at rated voltage) ; Current 1%(at rated current)
Analog monitor accuracy(V)	Constant Voltage mode : Voltage 5%(at rated voltage) ; Current 5%(at rated current) Optional Isolated : Voltage 1% (at rated voltage); Current 1%(at rated current)
Temp. Coefficient	100ppm/°C of rated output voltage, after a 30 minute warm-up
Temperature drift	0.05% of rated Vout over 8hrs interval following 30 minutes warm-up. Constant line, load & temp.
Command response time	$\leq 20\text{ms}$ (After received) (note.3)
Transient response time	Constant Voltage mode : 20V and under $\leq 1.5\text{ms}$ ; 30V~100V $\leq 1\text{ms}$ ; 150V~600V $\leq 2\text{ms}$ ;
Input voltage	750W /1500W type : 100~240Vac, 50/60Hz 3000W type : type. 190~240Vac, 50/60Hz
Input current (Full load)	750W type : 115Vac - 8.1A ; 230Vac - 4.1A ; 1500W type : 115Vac - 16.2A ; 230Vac - 8.1A ; 3000W type : 230Vac - 15.6A
Inrush current	750W type : 230Vac < 17A 1500W type : 230Vac < 33A 3000W type : 230Vac < 65A
Protective functions	Programmable over voltage protection(POVP), Programmable over current protection(POCP), Over temperature protection(OTP), Fuse blown protection
Over voltage /Over current programming range	0% ~ 110% of rated voltage ; 0% ~ 110% of rated rated current
Efficiency	750W type : 76% – 87% ; 1500W type : 77% – 88% ; 3000W type : 82% – 88%
Power Factor (PF)	0.99 (at 115Vac, rate output)
Withstand voltage	Input-Output - AC2000V:1 minute Input-Ground - AC2000V:1 minute
Weight	1UH type : approx. 5.1 kg, 1U type : approx. 9.0 kg 2UH type : approx. 8.2 kg, 2U type : approx. 15.1 kg
Noise	<70 dB(A)
Operating environment	750W series : Temperature : 0~40°C ; Humidity : 30%~90% RH(no condensation) 1.5kW and 3kW series : Temperature : 0~50°C ; Humidity : 30%~90% RH(no condensation)
Storage environment	Temperature : -20~70°C ; Humidity : 10%~90% RH (no condensation)
Cooling	Speed-Controlled Fan
EMI and Safety Certifications	CE Mark-full compliance with LVD and EMC directives

Note.1 : All parameters are specified base on power on after 30 minutes, Ambient temperature  $23 \pm 5^\circ\text{C}$  / Humidity : Under 80% RH, AC Voltage :  $\pm 5\%$ , Frequency :  $\pm 5\%$ .

Note 2. Programming time = Command response time + Output response time. The output response time is differ according to different models, from 30mS ~ 200mS

Note 3. The combined voltage should be lower than 600V when connect 2 units in series.

Note 4. Actual ramp down time will be different in different models.

Note 5. All specifications are subject to change without notice.

## Optional Accessories

### ■ DSP-OPT-IS05

Optional isolated analog interface (factory Installed)



### ■ DSP-OPT-488HR

Optional GPIB interface (factory Installed)



### ■ DSP-OPT-CAB50

25cm long for analog programming in parallel/series operation.



### ■ DSP-OPT-PAR

Socket board for parallel operation wiring

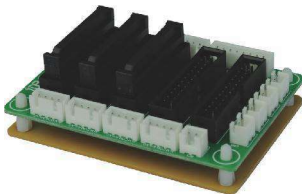

### ■ DSP-OPT-SER

Socket board for serial operation wiring.

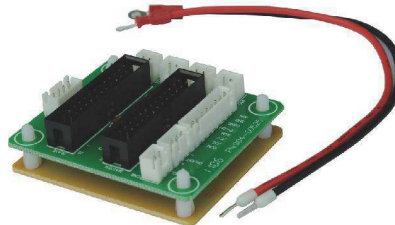

### ■ DSP-OPT-USB

USB to RS485 converter with USB cable(1m)



### ■ DSP-OPT-19HU2

Rack mount kit for installation of two 750W half rack units in 19" rack.



### ■ DSP-OPT-19HUR

Rack mount kit for installation of single 750W half rack unit in 19" rack.



### ■ DSP-OPT-CAB22

DSP-HR AC input cable for 1500W and 3000W, 3x12AWG(2 wire+G), 2m



### ■ DSP-OPT-SLD

Sliding rail for 1U/2U models



GUI software

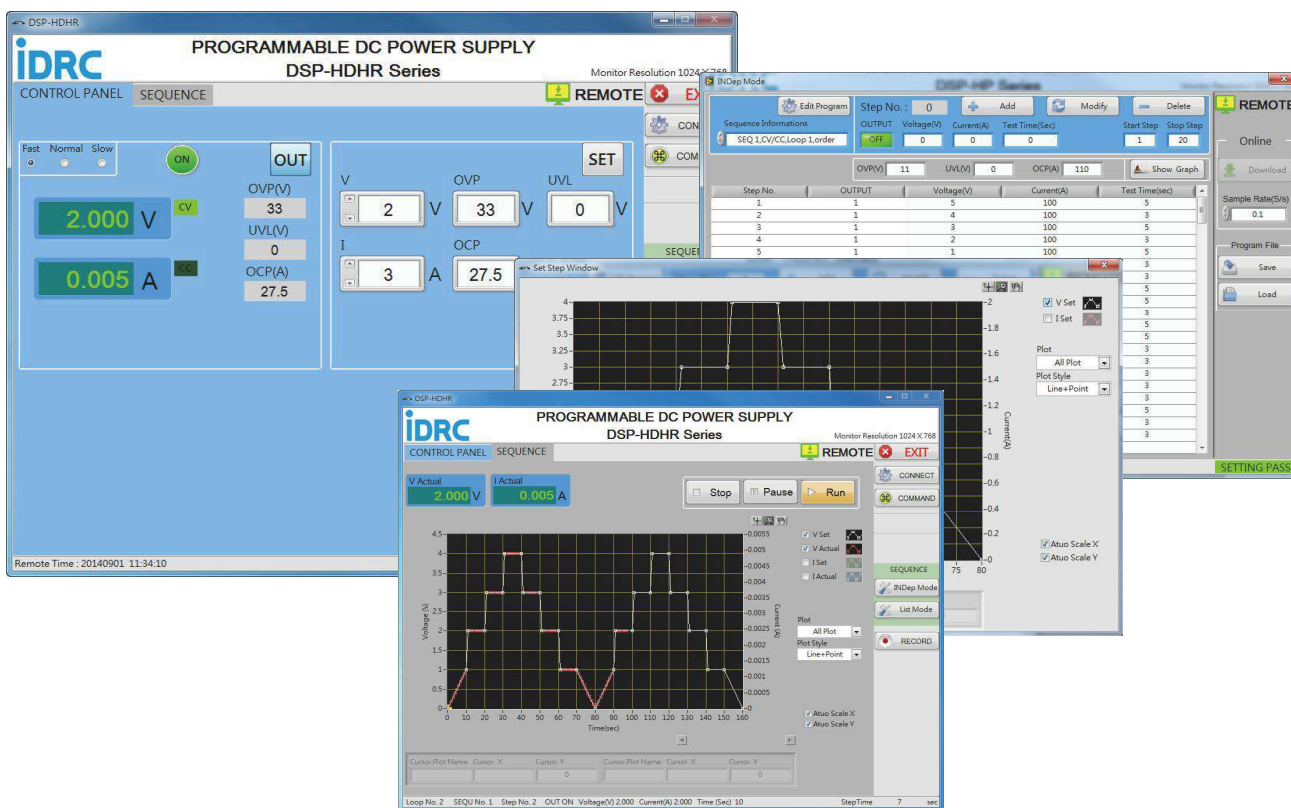

Outline Diagram - 1U (mm)

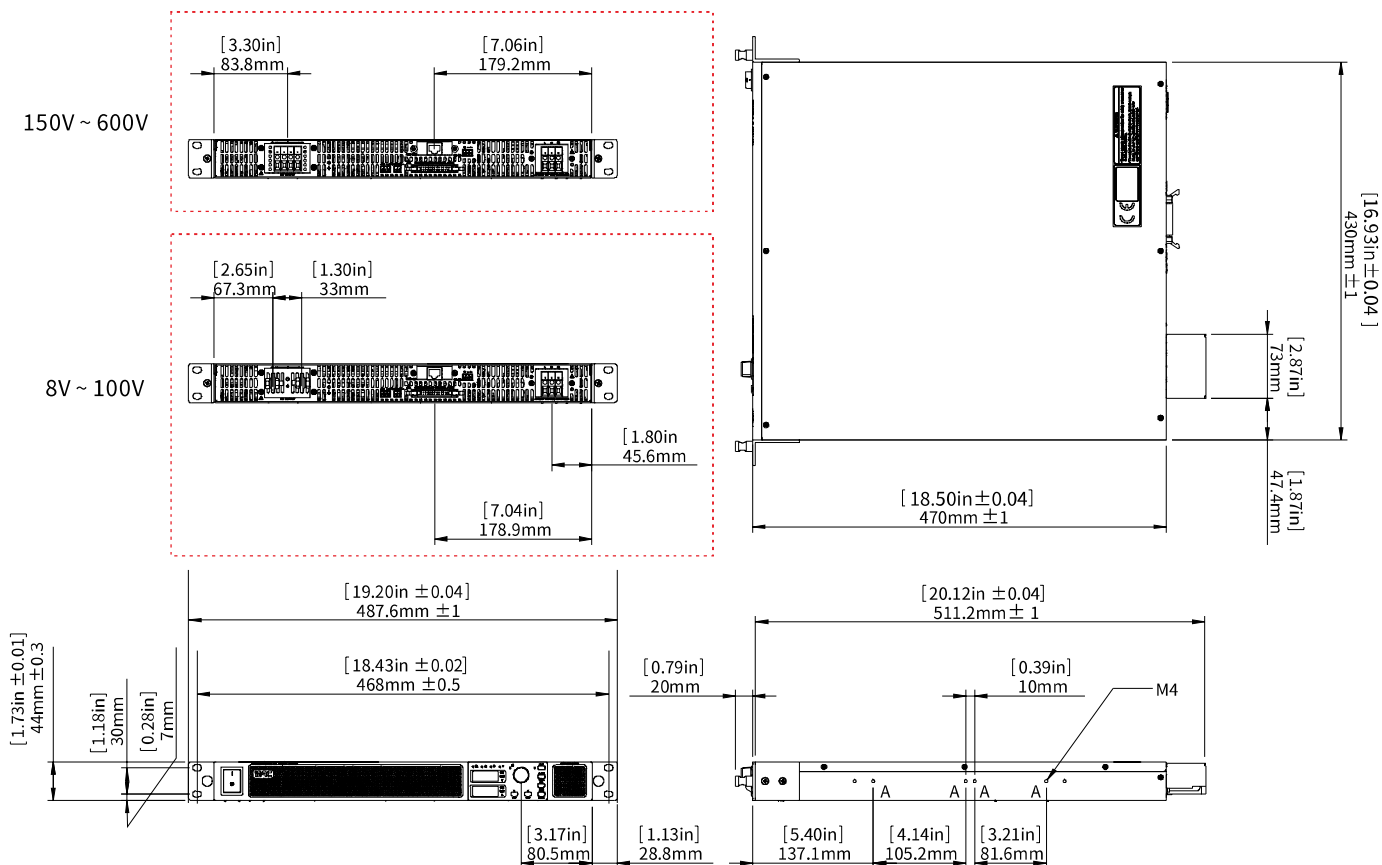

**Outline Diagram - 2U (mm)**

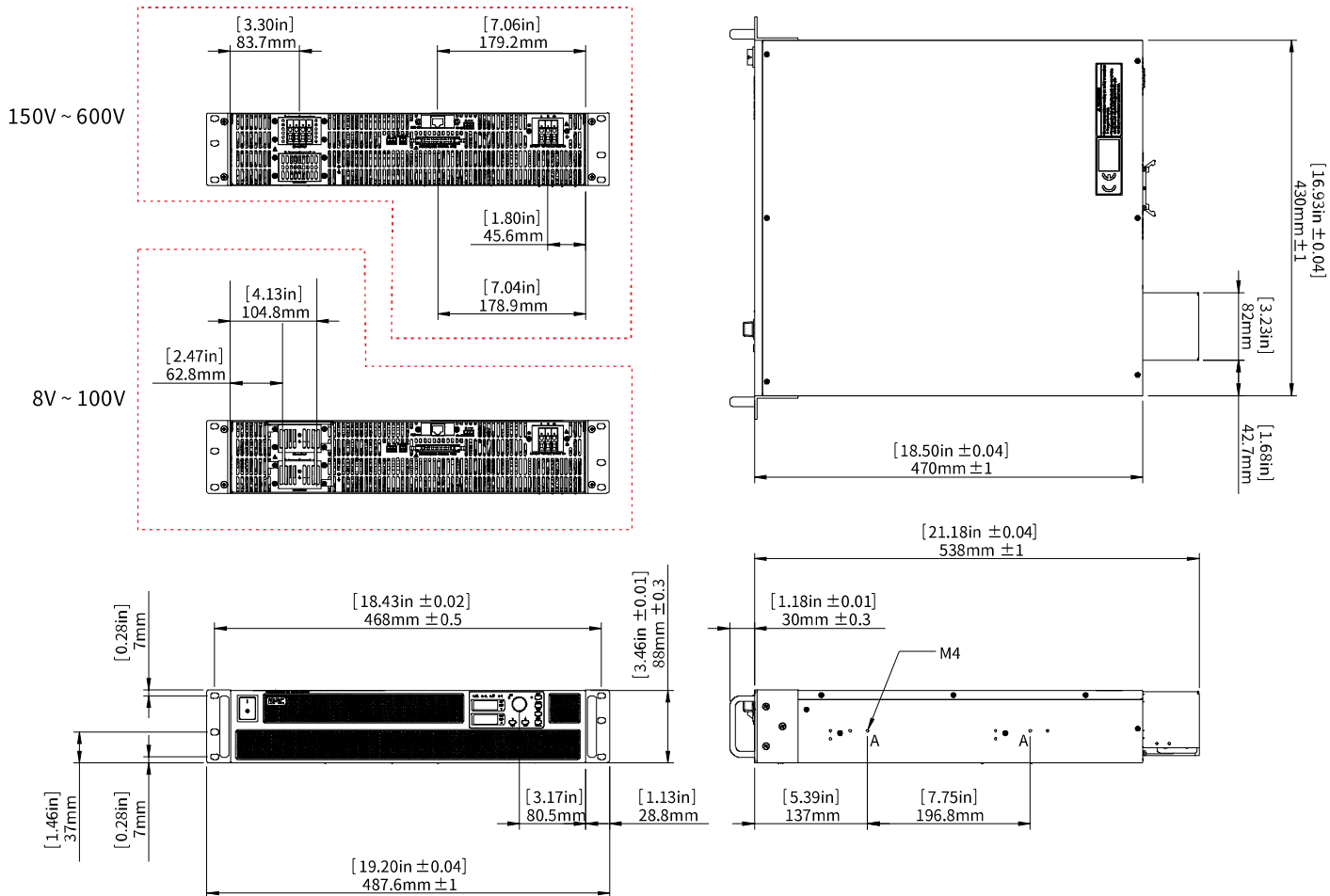

**Outline Diagram - 1UH (mm)**

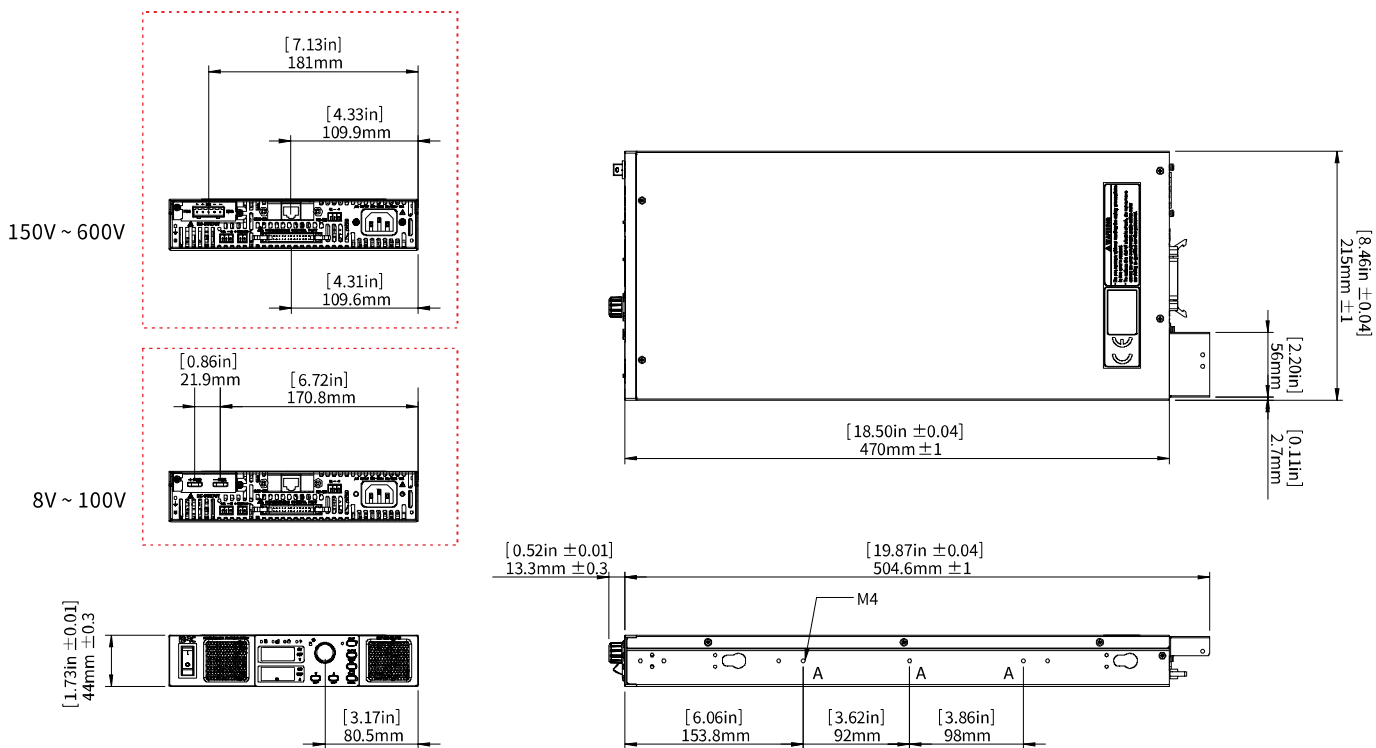

**Outline Diagram - 2UH (mm)**

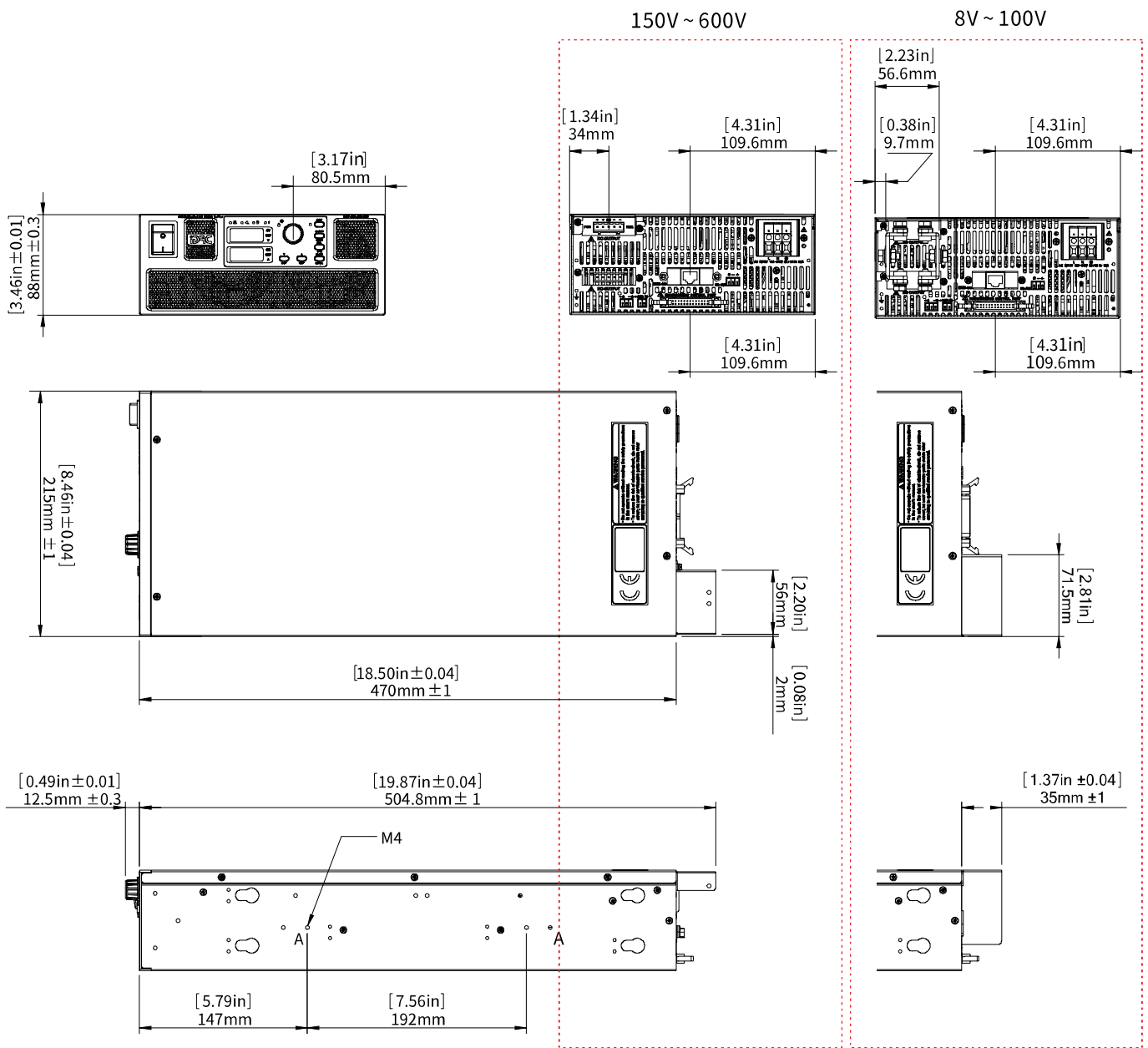



**VP** ELECTRONIQUE